

I, DAVID H. SNIDER, CERTIFY THAT THIS PLAT WAS PREPARED UNDER MY SUPERVISION AND THAT THE PLAT WAS PREPARED FOR THE PURPOSE OF EASEMENTS ONLY, AND IS NOT INTENDED TO BE A BOUNDARY SURVEY OF PROPERTY SHOWN.

David H. Snider 6/3/15
 DAVID H. SNIDER, NC P.L.S. L-2942 DATE



COMBINED GRID
 FACTOR=0.999839812
 N: 572569.23
 E: 1449910.73

LEGEND

- #5 REBAR FOUND
- CALCULATED POINT
- LINES SURVEYED
- LINES NOT SURVEYED
- TEMP. CONSTRUCTION EASEMENT
- PERMANENT SHELTER EASEMENT
- SIDEWALK UTILITY EASEMENT

- 1) BEARINGS AND DISTANCES SHOWN IN PARENTHESSES ARE BASED ON RECORDED MAP INFORMATION.
- 2) TOTAL AREA 183,055 SQ. FT.
- 3) TEMP. CONSTRUCTION EASEMENT 472 SQ. FT.
- 4) PERMANENT SHELTER EASEMENT 224 SQ. FT.
- 5) SIDEWALK UTILITY EASEMENT 152 SQ. FT.
- 6) AREA REMAINING 183,055 SQ. FT.

12) 037-192-23
 MCDONALDS CORP
 06070-419
 5005 SUNSET RD

16) 037-192-30
 FERGUSON ENTERPRISES INC.
 DB 23054 PG 14
 SUNSET RD.

22) 037-192-05
 SPIRIT FG CHARLOTTE NC LLC.
 DB 28720 PG 176
 5025 SUNSET RD.

18) 037-192-28
 USF HOLLAND INC
 DB 16755 PG 982
 SUNSET RD.

19) 037-192-02
 USF HOLLAND INC
 DB 10211-501
 5201 SUNSET RD

NC GRID NAD 83/2001 VRS

PREPARED BY:
 CITY OF CHARLOTTE
 ENGINEERING & PROPERTY
 MANAGEMENT DEPARTMENT
 600 EAST FOURTH STREET
 CHARLOTTE, NC 28202
 704-336-2291

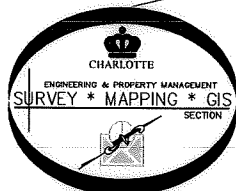

N18°46'07"W 19.34'
 (N18°16'28"W 19.38')
 #6 REBAR
 #5 REBAR
 S76°16'05"W 280.12'
 (S76°14'16"W 280.33')

STATE OF NORTH CAROLINA
 COUNTY OF MECKLENBURG

I, _____, REVIEW OFFICER OF MECKLENBURG COUNTY, CERTIFY THAT THE MAP OR PLAT TO WHICH THIS CERTIFICATION IS AFFIXED MEETS ALL STATUTORY REQUIREMENTS FOR RECORDING.

REVIEW OFFICER _____ DATE _____

		CHARLOTTE ENGINEERING & PROPERTY MANAGEMENT DEPARTMENT	
REVISIONS		SUNSET RD. SIDEWALK PROJECT	JOB NO. 512-07-055
6/2/15 TCE & SUE EDIT 12/18/14 LEGEND			207055
SCALE 1"=80" 		PROPERTY OF FERGUSON ENTERPRISES INC. CHARLOTTE, MECKLENBURG CO., NC	SHEET 1
DRAWN BY P.S.			OF 2
DATE	CHECKED BY DS	SURVEY SUPVR. <i>ZHL</i>	
K: \AutoCad\En_su-LD4\207055 sunset Rd\PLATS\#16 037-192-30.dwg			

I, DAVID H. SNIDER, CERTIFY THAT THIS PLAT WAS PREPARED UNDER MY SUPERVISION AND THAT THE PLAT WAS PREPARED FOR THE PURPOSE OF EASEMENTS ONLY, AND IS NOT INTENDED TO BE A BOUNDARY SURVEY OF PROPERTY SHOWN.

David H. Snider 6/3/15
 DAVID H. SNIDER, NC P.L.S. L-2942 DATE



STATE OF NORTH CAROLINA
 COUNTY OF MECKLENBURG

I, _____, REVIEW OFFICER OF MECKLENBURG COUNTY, CERTIFY THAT THE MAP OR PLAT TO WHICH THIS CERTIFICATION IS AFFIXED MEETS ALL STATUTORY REQUIREMENTS FOR RECORDING.

REVIEW OFFICER _____ DATE _____

Line Table		
Line #	Length	Direction
L1	2.90	N13°55'35"W
L2	5.00	N76°06'16"E
L3	27.98	N76°06'16"E
L4	18.01	N76°06'16"E
L5	3.05	S13°51'31"E
L6	3.95	S13°51'31"E
L7	10.00	N75°58'38"E
L8	12.04	S13°45'50"E
L9	41.02	N76°13'30"E
L10	16.06	N13°55'35"W
L11	8.05	N13°55'35"W
L12	28.00	N76°13'30"E
L13	7.99	S13°46'30"E
L14	50.98	S76°16'05"W
L15	128.04	S76°16'05"W

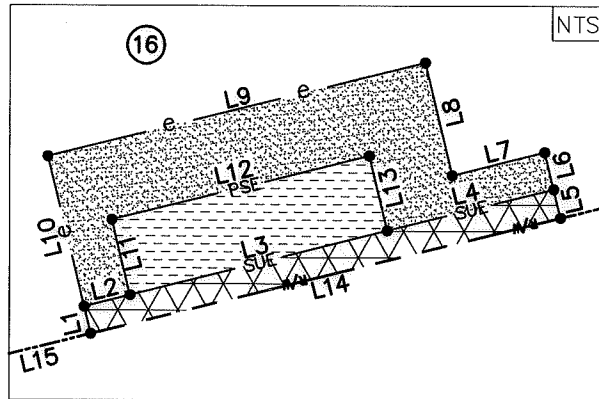

NC GRID NAD 83/2001 VRS

PREPARED BY:
 CITY OF CHARLOTTE
 ENGINEERING & PROPERTY
 MANAGEMENT DEPARTMENT
 600 EAST FOURTH STREET
 CHARLOTTE, NC 28202
 704-336-2291



CHARLOTTE ENGINEERING & PROPERTY MANAGEMENT DEPARTMENT		
REVISIONS 6/2/15 TCE & SUE EDIT 12/18/14 LEGEND SCALE 1" = 80" 	SUNSET RD. SIDEWALK PROJECT PROPERTY OF FERGUSON ENTERPRISES INC. CHARLOTTE, MECKLENBURG CO., NC	JOB NO. 512-07-055 207055 SHEET 2 OF 2
DRAWN BY P.S. DATE _____	CHECKED BY DS _____ SURVEY SUPVR. <i>DS</i>	
K:\AutoCad\En_su-LD4\207055 sunset Rd\PLATS\#16 037-192-30.dwg		