

| LINE | DIRECTION | DISTANCE |
|------|-----------------|------------|
| L1 | N 21° 00' 56" E | 7.94 FT. |
| L2 | N 39° 35' 44" E | 57.76 FT. |
| L3 | N 75° 30' 09" E | 17.20 FT. |
| L4 | N 39° 35' 40" E | 114.96 FT. |
| L5 | N 31° 44' 49" E | 78.09 FT. |
| L6 | N 41° 39' 21" W | 64.74 FT. |
| L7 | N 47° 49' 30" W | 136.77 FT. |
| L8 | N 58° 58' 31" W | 59.95 FT. |
| L9 | N 25° 34' 55" E | 21.90 FT. |
| L10 | S 47° 39' 54" E | 43.66 FT. |
| L11 | S 47° 16' 47" E | 50.84 FT. |
| L12 | S 47° 48' 02" E | 48.71 FT. |
| L13 | S 48° 14' 34" E | 46.65 FT. |
| L14 | S 49° 33' 29" E | 50.58 FT. |
| L15 | S 47° 25' 33" E | 23.29 FT. |
| L16 | S 47° 25' 33" E | 34.71 FT. |
| L17 | S 39° 34' 33" W | 288.31 FT. |
| L18 | N 48° 21' 18" W | 9.29 FT. |
| L19 | N 48° 21' 18" W | 22.57 FT. |
| L20 | N 39° 35' 39" E | 186.70 FT. |
| L21 | N 34° 21' 44" E | 88.27 FT. |
| L22 | N 9° 20' 43" W | 23.11 FT. |

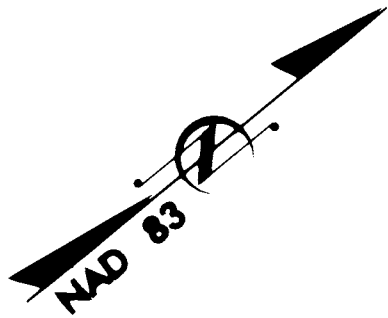

39

THE ALEXANDER/MYERS
FAMILY PARTNERSHIP
OLD STATESVILLE RD.
DB 7018 PG 169
TAX #03720305

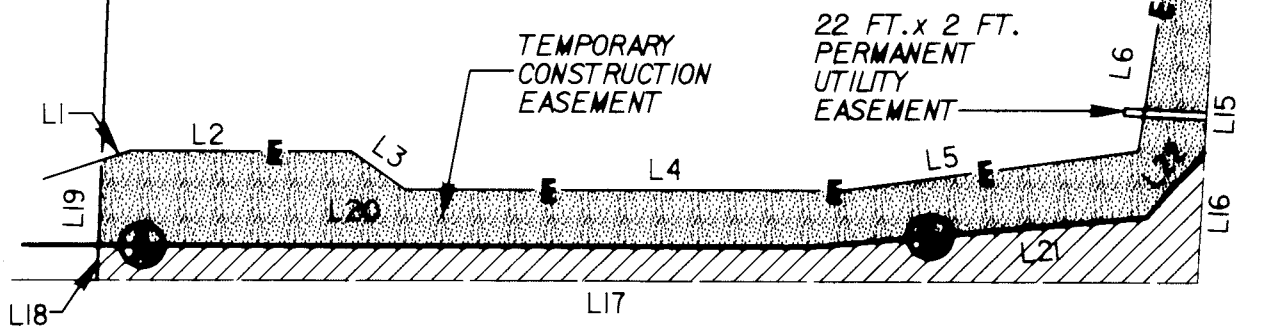

I, MARK FUNKHOUSER, CERTIFY THAT THIS PLAT WAS PREPARED UNDER MY SUPERVISION AND THAT THE PLAT WAS PREPARED FOR THE PURPOSE OF ACQUISITION AND EASEMENTS ONLY, AND IS NOT INTENDED TO BE A BOUNDARY SURVEY OF PROPERTY SHOWN

mlp/lla 3-27-01



LEGEND

- EXISTING IRON PIN
- SET IRON PIN
- NEW PROPERTY LINE
- AREA ACQUIRED
- TEMPORARY CONSTRUCTION EASEMENT

PBSJ Plans Prepared By
200 EAST WOODLAWN ROAD, SUITE 300
CHARLOTTE, NORTH CAROLINA 28207

| | | |
|--|---------------|-------------------------|
| CHARLOTTE ENGINEERING AND PROPERTY MANAGEMENT | | JOB NO. 512-00-016 |
| OLD STATESVILLE ROAD WIDENING PROJECT | | FILE NO. PLAT 98 |
| PROPERTY ACQUISITION THE ALEXANDER/MYERS FAMILY PARTNERSHIP CHARLOTTE, MECKLENBURG CO., NC | | SHEET 2 OF |
| DATE: 3/27/01 | SCALE: 1"=50' | 2 |