

OLD STATESVILLE ROAD

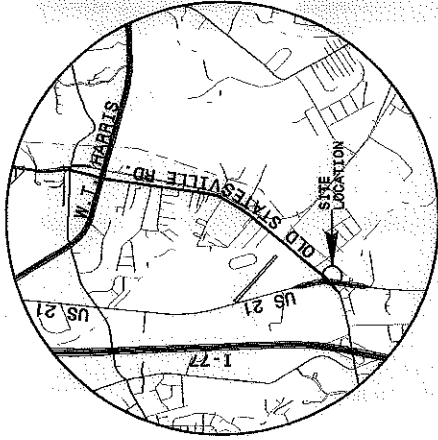

VICINITY  
N.T.S.

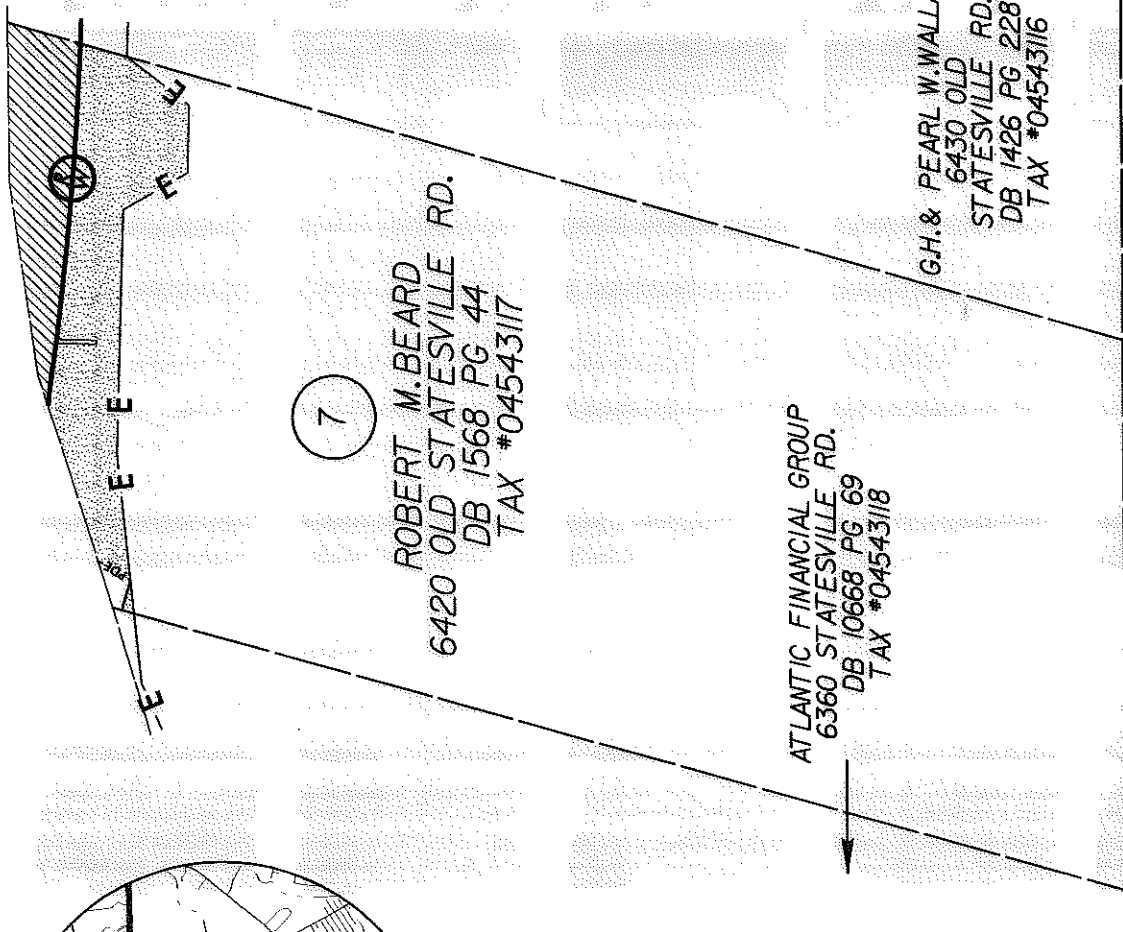

ROBERT M. BEARD  
6420 OLD STATESVILLE RD.  
DB 1568 PG 44  
TAX #04543117

ATLANTIC FINANCIAL GROUP  
6360 STATESVILLE RD.  
DB 10668 PG 69  
TAX #04543118

G.H. & PEARL W. WALLACE  
6430 OLD STATESVILLE RD.  
DB 1426 PG 228  
TAX #04543116



AREA FROM DEED OR TAX OFFICE	AREA ACQUIRED (OUTSIDE R/W)	AREA ACQUIRED (WITHIN R/W)	RECORD AREA LESS AREA ACQUIRED
174,240 SQ. FT. 4.000 ACRES	4,876 SQ. FT. 0.112 ACRES	11,070 SQ. FT. 0.254 ACRES	158,294 SQ. FT. 3.634 ACRES

TEMPORARY CONSTRUCTION AREA	PERMANENT DRAINAGE EASEMENT	PERMANENT UTILITY EASEMENT
9,445 SQ. FT. 0.217 ACRES	206 SQ. FT. 0.005 ACRES	40 SQ. FT.

I, MARK FUNKHOUSER, CERTIFY THAT THIS PLAT WAS PREPARED UNDER MY SUPERVISION AND THAT THE PLAT WAS PREPARED FOR THE PURPOSE OF ACQUISITION AND EASEMENTS ONLY, AND IS NOT INTENDED TO BE A BOUNDARY SURVEY OF PROPERTY SHOWN

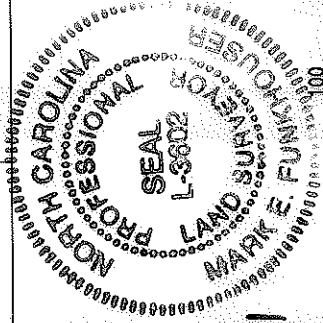

*Mark E. Funkhouser* 8-27-01

LEGEND

- EXISTING IRON PIN
- SET IRON PIN
- NEW PROPERTY LINE
- AREA ACQUIRED
- TEMPORARY CONSTRUCTION EASEMENT

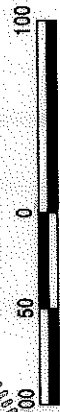

**CHARLOTTE**  
ENGINEERING AND PROPERTY MANAGEMENT

REVISIONS  
8/27/01

JOB NO. 512-99-015  
FILE NO. PLAT 7  
SHEET 1 OF 2

OLD STATESVILLE ROAD WIDENING PROJECT

PROPERTY ACQUISITION  
ROBERT M. BEARD

CHARLOTTE, MECKLENBURG CO., NC  
DATE: 4/23/01 SCALE: 1"=100'

DRAWN BY: CTC/CRT  
CHECKED BY: MED  
SURVEY SURV.

ACQUISITION BY DB 15520 PG 611

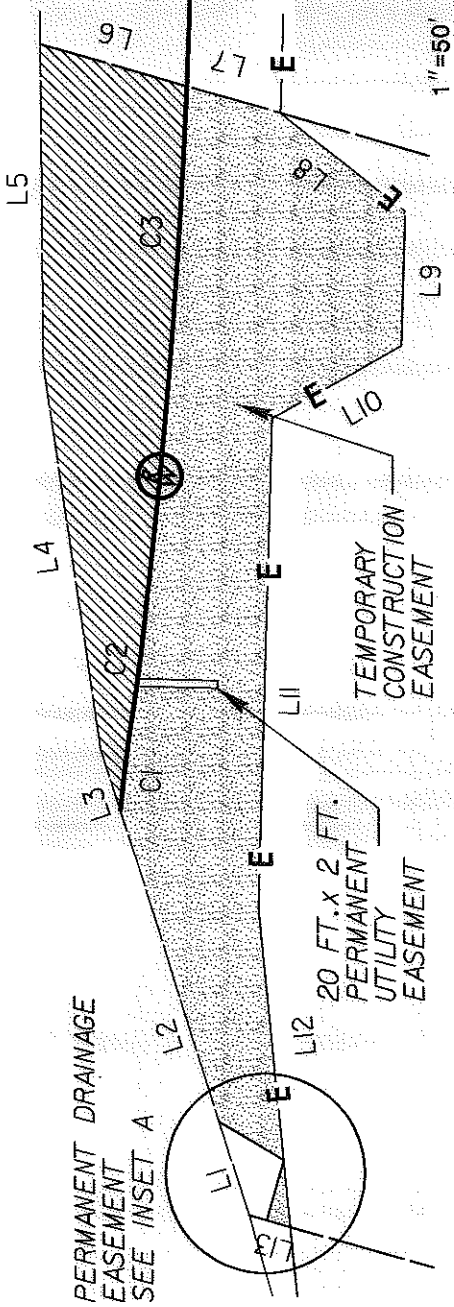

LINE	DIRECTION	DISTANCE
L1	N 21° 42' 13" E	25.58 FT.
L2	N 21° 42' 13" E	84.88 FT.
L3	N 21° 42' 13" E	17.22 FT.
L4	N 30° 58' 42" E	100.98 FT.
L5	N 38° 47' 25" E	83.45 FT.
L6	S 34° 35' 33" E	39.54 FT.
L7	S 34° 35' 33" E	25.30 FT.
L8	S 12° 21' 49" E	41.48 FT.
L9	S 40° 56' 36" W	34.96 FT.
L10	N 79° 48' 53" W	38.70 FT.
L11	S 40° 56' 37" W	127.61 FT.
L12	S 33° 31' 34" W	83.49 FT.
L13	N 34° 53' 33" W	6.45 FT.
L14	S 19° 57' 13" E	19.60 FT.
L15	S 55° 06' 24" W	16.30 FT.
L16	N 34° 53' 33" W	4.86 FT.

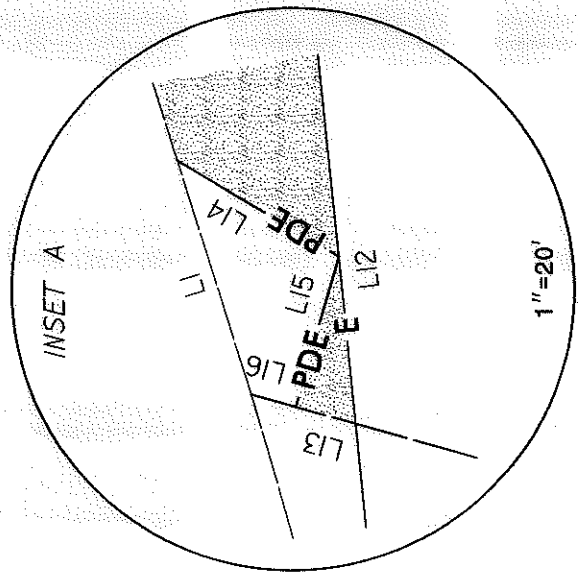

CURVE	RADIUS	LENGTH	CHORD	BEARING
C1	484.00 FT.	19.94 FT.	19.94 FT.	N 45° 54' 15" E
C2	616.00 FT.	37.34 FT.	37.33 FT.	N 46° 30' 32" E
C3	1762.95 FT.	133.00 FT.	133.03 FT.	N 43° 38' 07" E

I, MARK FUNKHOUSER, CERTIFY THAT THIS PLAT WAS PREPARED UNDER MY SUPERVISION AND THAT THE PLAT WAS PREPARED FOR THE PURPOSE OF ACQUISITION AND EASEMENTS ONLY, AND IS NOT INTENDED TO BE A BOUNDARY SURVEY OF PROPERTY SHOWN

*Mark E. Funkhouser* 8-27-01

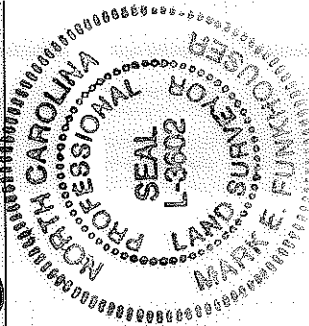

- LEGEND**
- EXISTING IRON PIN
  - ⊙ SET IRON PIN
  - NEW PROPERTY LINE
  - ▨ AREA ACQUIRED
  - ▤ TEMPORARY CONSTRUCTION EASEMENT

		JOB NO. 512-99-015	FILE NO. PLAT 7	SHEET 2	OF 2
		OLD STATESVILLE ROAD WIDENING PROJECT			
REVISIONS 8/27/01		PROPERTY ACQUISITION ROBERT M. BEARD			
DRAWN BY: CTD/CRT CHECKED BY: WED		CHARLOTTE, MECKLENBURG CO., NC			
SURVEY SUPVR.		DATE: 4/23/01 SCALE: N/A			