

I, JACKIE W. BRIM, CERTIFY THAT THIS PLAT WAS PREPARED UNDER MY SUPERVISION AND THAT THE PLAT WAS PREPARED FOR THE PURPOSE OF ACQUISITION AND EASEMENTS ONLY, AND IS NOT INTENDED TO BE A BOUNDARY SURVEY OF PROPERTY SHOWN.

Jackie W. Brim 11-3-2016

JACKIE W. BRIM, NC P.L.S. L-4348 DATE

NOTE:

- 1) BEARINGS AND DISTANCE SHOWN IN PARENTHESIS ARE BASED ON RECORDED INFORMATION.
- 2) COMPUTED PROJECT DISTANCE - *
- 3) TOTAL AREA 40,746 SQ.FT.
- 4) TEMP. CONSTRUCTION EASEMENT 4,684 SQ.FT.
- 5) SIDEWALK/UTILITY EASEMENT 1,015 SQ.FT.
- 6) FEE SIMPLE INSIDE R/W BY MAINTENANCE 4,706 SQ.FT.
- 7) TOTAL AREA REMAINING 36,040 SQ.FT.

LINE TABLE		
LINE	LENGTH	BEARING
L1	3.00'	N 56°13'41" E
L2	46.20'	S 33°46'19" E
L3	2.64'	S 37°19'47" E
L4	34.47'	S 80°36'36" E
L5	51.77'	S 35°08'21" E
L6	57.30'	S 15°31'33" E

05534106
TRUSTEES OF COVENANT
UNITED METHODIST CHURCH
DB 4731/PG 843
3540 AND 6824
TUCKASSGEE ROAD

LEGEND

REBAR OR IRON PIN FOUND

COMPUTED POINT

PROPERTY LINES

EXISTING RIGHT-OF-WAY

R/W BY MAINTENANCE

FEE SIMPLE INSIDE R/W BY MAINTENANCE

TEMP. CONSTRUCTION EASEMENT

SIDEWALK/UTILITY EASEMENT

PREPARED BY:
CITY OF CHARLOTTE
ENGINEERING & PROPERTY MANAGEMENT DEPARTMENT
600 EAST FOURTH STREET
CHARLOTTE, NC 28202
704-336-2291

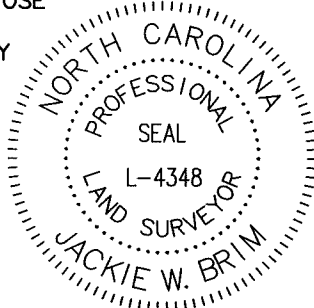
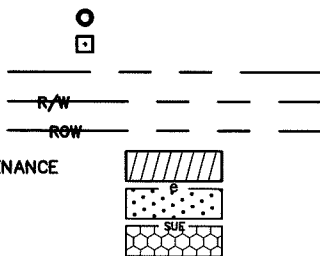

⑪
05534117
PON EY TIEU AND
WIFE SOPHY C. TIEU
DB 24013/PG 23
2134 LITTLE ROCK ROAD

MAG. NAIL
NC GRID NAD 83 (2011)
N: 553,778.78 FEET
E: 1,420,651.51 FEET
CGF: 0.9998415

⑩
05534116
PON EY TIEU AND
WIFE SOPHY C. TIEU
DB 14847/PG 422
2208 LITTLE ROCK ROAD

⑧
05534115
CURTIS FLUITT
DB 20937/PG 695
2216 LITTLE ROCK ROAD

STATE OF NORTH CAROLINA
COUNTY OF MECKLENBURG

I, _____, REVIEW OFFICER
OF MECKLENBURG COUNTY, CERTIFY THAT
THE MAP OR PLAT TO WHICH THIS
CERTIFICATION IS AFFIXED MEETS ALL
STATUTORY REQUIREMENTS FOR RECORDING.

REVIEW OFFICER _____ DATE _____

COMPUTED POINT
N: 550,859.94 FEET
E: 1,420,988.85 FEET

(N 24°25'00" W 103.92')
(N 25°40'10" W 103.92')
(N 56°35'34" W 2938.73' (GROUND)
2938.26' (GRID)

(N 56°35'00" E 322.86')
(N 55°10'39" E 322.49' (TOTAL)
228.80'

(S 25°52'12" E 70.01' (TIE)
S 61°55'07" W 333.60' (TOTAL)
(S 63°19'36" W 333.60')

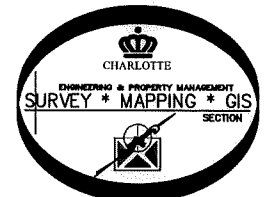
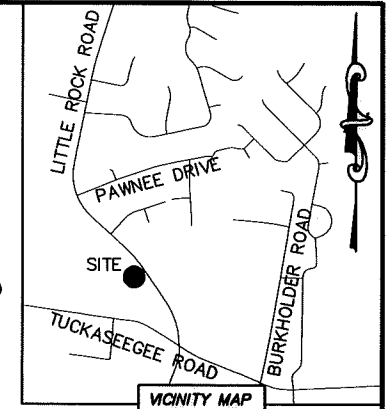
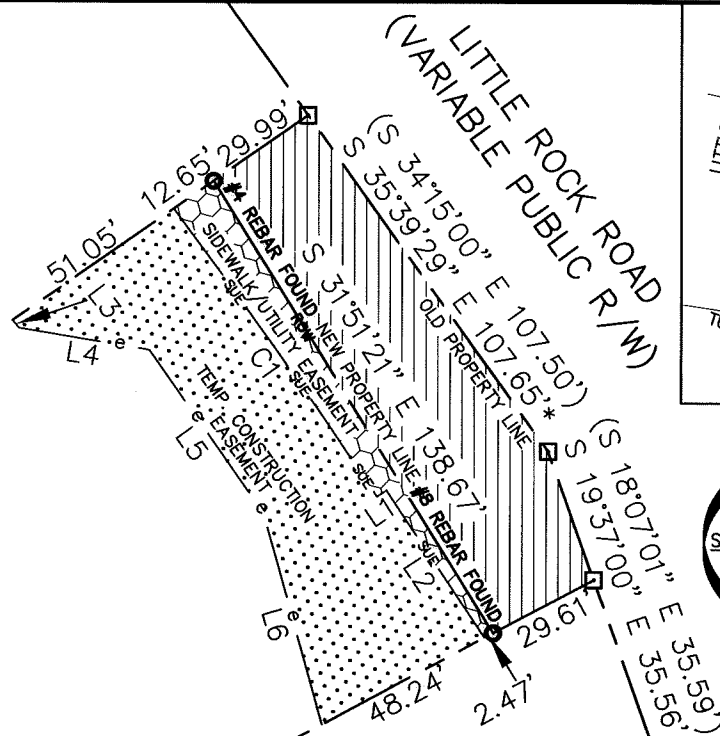

CURVE TABLE		
CURVE	RADIUS & ARC	CHORD
C1	R=1657.00 L=91.97'	S 35°21'40" E 91.95'

CHARLOTTE ENGINEERING & PROPERTY MANAGEMENT DEPARTMENT		
REVISIONS	LITTLE ROCK ROAD SIDEWALK PROJECT	JOB NO. PM51215018
		FILE NO. 055-341-16
SCALE 1"=50'		PROPERTY OF PON EY TIEU AND WIFE SOPHY C. TIEU CHARLOTTE, MECKLENBURG CO., NC
DRAWN BY LG		SHEET 1
DATE	CHECKED BY JWB	OF 1
		SURVEY SUPVR.

K:\AutoCad\En_su-LD4\215018\dwg\LITTLEROCKROADSIDEWALKPLAST.DWG

DB 31710-956