

I, _____, REVIEW OFFICER OF MECKLENBURG COUNTY, CERTIFY THAT THE MAP OR PLAT TO WHICH THIS CERTIFICATION IS AFFIXED MEETS ALL STATUTORY REQUIREMENTS OF NORTH CAROLINA GENERAL STATUTES FOR RECORDING.

REVIEW OFFICER _____ DATE _____

LEGEND

- TCE = TEMPORARY CONSTRUCTION EASEMENT
- SUE = PERMANENT SIDEWALK AND UTILITY EASEMENT
- SDE = PERMANENT STORM DRAINAGE EASEMENT

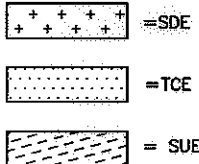

- e — = TCE
- R/W- - - - = EXISTING R/W
- SUE — = SUE
- SDE — = SDE
- = IRON PIN FOUND

LINE	LENGTH	BEARING
L1	50.00	N03°02'47"E
L2	9.83	S85°56'21"W
L3	10.83	S85°56'21"W
L4	70.43	N08°12'30"W
L5	72.85	N02°44'30"W
L6	7.89	N03°15'43"E
L7	11.53	N89°50'43"E
L8	9.68	N89°50'43"E
L9	5.62	N87°58'29"E
L10	7.00	N87°58'29"E
L11	19.66	N02°28'44"W
L12	7.00	S87°04'03"W
L13	3.73	S87°04'03"W
L14	2.34	S03°02'47"W
L15	19.57	S03°02'47"W
L16	28.09	S03°02'47"W

CURVE	LENGTH	RADIUS	CHORD BRG	CHORD DIST
C1	13.34	58.00	S05°53'23"E	13.31
C2	7.90	42.00	N07°05'06"W	7.89
C3	7.16	1235.00	S01°51'33"E	7.16
C4	19.55	1235.00	S02°28'44"E	19.55
C5	94.56	1235.00	S05°07'33"E	94.53
C6	4.42	42.00	N04°18'25"W	4.41
C7	3.30	58.00	S02°55'35"E	3.30

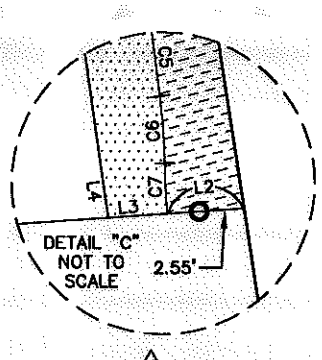
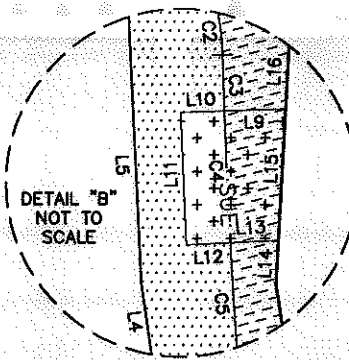
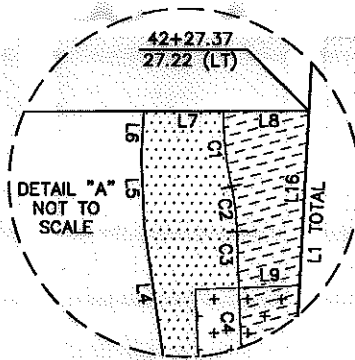

- NOTE:
- 1) BEARINGS AND DISTANCES SHOWN IN PARENTHESES ARE BASED ON RECORDED MAP OR DEED INFORMATION.
 - 2) TOTAL AREA: 118,928 SF, 2.730 AC
 - 3) AREA IN TCE: 1,800 SF, 0.041 AC
 - 4) AREA IN SUE: 1,021 SF, 0.023 AC
 - 5) AREA IN SDE: 229 SF, 0.005 AC
 - 6) AREA OF SDE AND SUE OVERLAP: 92 SF, 0.006 AC
 - 7) FEE AREA REMAINING: 118,928 SF, 2.730 AC

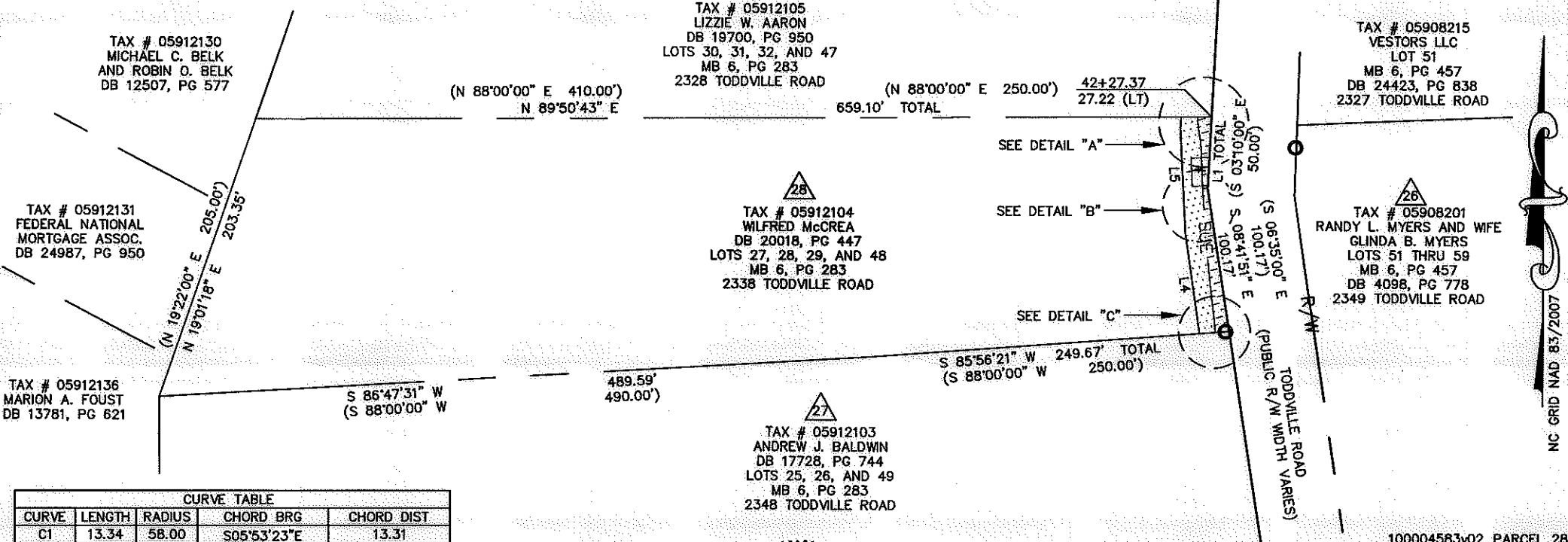
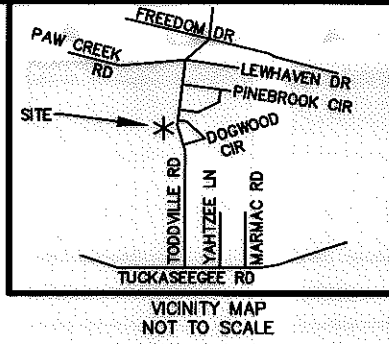

I, CHARLES J. DUNBAR, CERTIFY THAT THIS PLAT WAS PREPARED UNDER MY SUPERVISION AND THAT THIS PLAT WAS PREPARED FOR THE PURPOSE OF EASEMENTS ONLY, AND IS NOT INTENDED TO BE A BOUNDARY SURVEY OF PROPERTY SHOWN.

CHARLES J. DUNBAR NC PLS L-4159 7/9/10 DATE

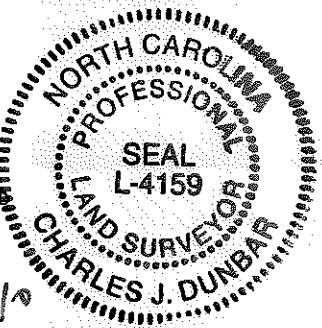

PBSJ Plans Prepared By:
 5200 77 CENTER DRIVE, SUITE 500
 CHARLOTTE, NORTH CAROLINA 28217
 (704) 522-7275 NCCOA: F-0326

CHARLOTTE ENGINEERING DEPARTMENT		JOB NO. 512-08-024
REVISIONS 1) 7/9/10 ADDED OVERLAP AREA	TODDVILLE ROAD SIDEWALK	FILE NO. PARCEL 28
SCALE 1" = 40' 0' 40'	PROPERTY ACQUISITION OWNER: WILFRED McCREA CHARLOTTE, MECKLENBURG CO., NC	SHEET 1 OF 1
DRAWN BY: TTB	CHECKED BY: CJD	SURVEY SUPVR.: CJD
DATE: 06/22/2010		

NC GRID NAD 83/2007

100004583v02_PARCEL 28