

I, DAVID H. SNIDER, CERTIFY THAT THIS PLAT WAS PREPARED UNDER MY SUPERVISION AND THAT THE PLAT WAS PREPARED FOR THE PURPOSE OF ACQUISITION AND EASEMENTS ONLY, AND IS NOT INTENDED TO BE A BOUNDARY SURVEY OF PROPERTY SHOWN.

*David H. Snider* 8/2/2010

DAVID H. SNIDER, NC P.L.S. L-2942 DATE

STATE OF NORTH CAROLINA  
COUNTY OF MECKLENBURG

I, \_\_\_\_\_ REVIEW OFFICER OF MECKLENBURG COUNTY, CERTIFY THAT THE MAP OR PLAT TO WHICH THIS CERTIFICATION IS AFFIXED MEETS ALL STATUTORY REQUIREMENTS FOR RECORDING.

REVIEW OFFICER \_\_\_\_\_ DATE \_\_\_\_\_

NOTE:

- 1) BEARINGS AND DISTANCE SHOWN IN PARENTHESIS ARE BASED ON RECORDED INFORMATION.
- 2) TOTAL AREA 193,365 SQ.FT.
- 3) UTILITY EASEMENT 94 SQ.FT.
- 4) TOTAL AREA REMAINING 193,365 SQ.FT.
- 5) SEE PAGE TWO FOR DETAILS AND TABLES.

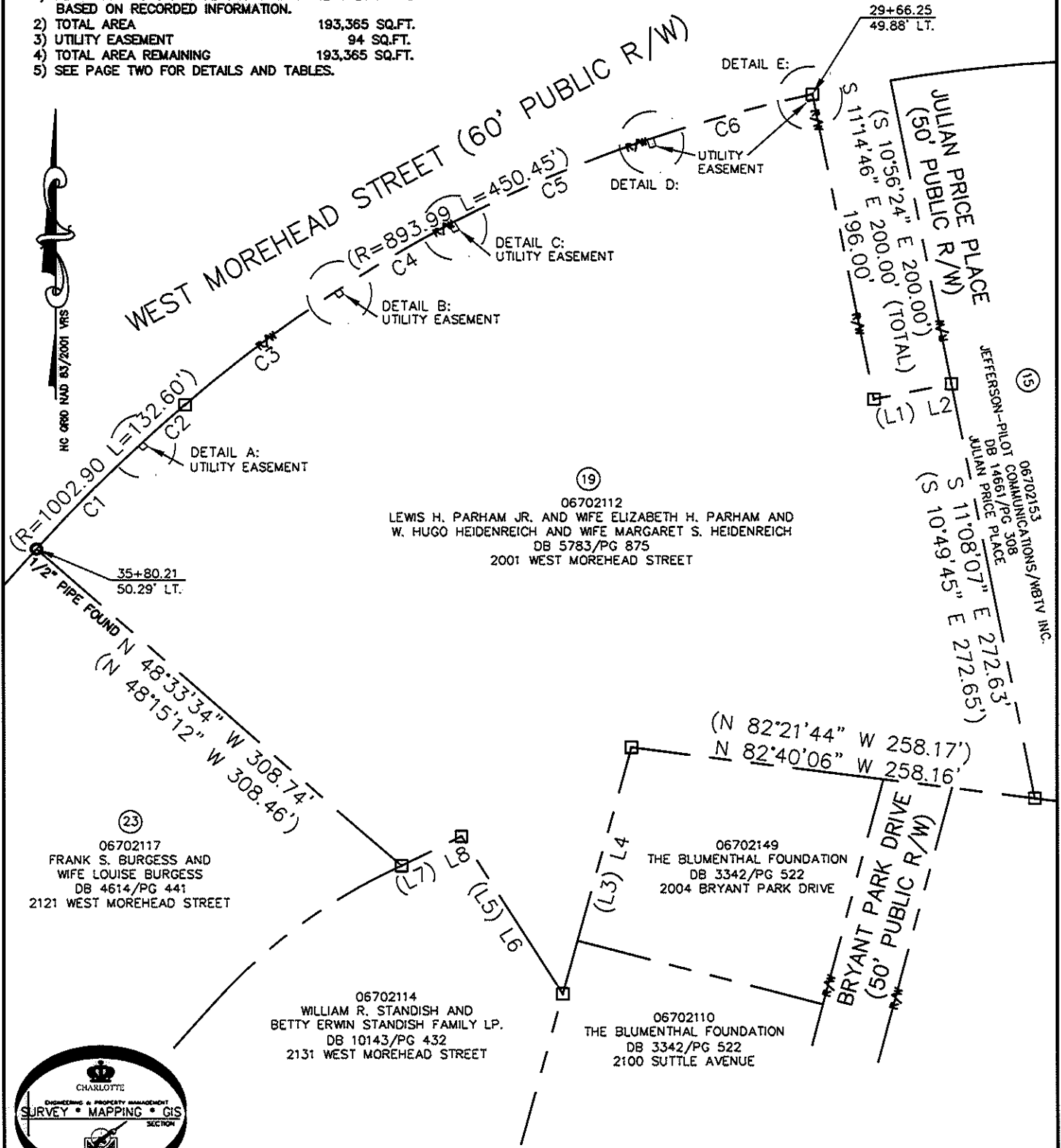
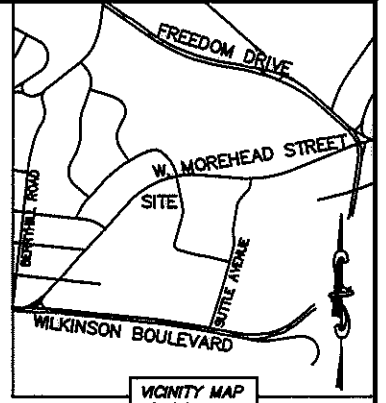
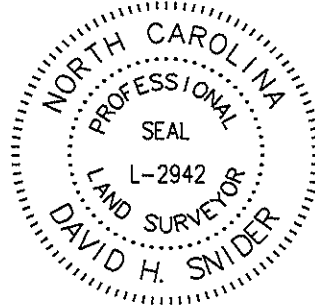

06702112  
LEWIS H. PARHAM JR. AND WIFE ELIZABETH H. PARHAM AND  
W. HUGO HEIDENREICH AND WIFE MARGARET S. HEIDENREICH  
DB 5783/PG 875  
2001 WEST MOREHEAD STREET

06702117  
FRANK S. BURGESS AND  
WIFE LOUISE BURGESS  
DB 4614/PG 441  
2121 WEST MOREHEAD STREET

06702114  
WILLIAM R. STANDISH AND  
BETTY ERWIN STANDISH FAMILY LP.  
DB 10143/PG 432  
2131 WEST MOREHEAD STREET

06702110  
THE BLUMENTHAL FOUNDATION  
DB 3342/PG 522  
2100 SUTTLE AVENUE

06702149  
THE BLUMENTHAL FOUNDATION  
DB 3342/PG 522  
2004 BRYANT PARK DRIVE

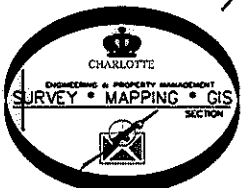

LEGEND

- REBAR OR IRON PIN FOUND
- COMPUTED POINT
- PROPERTY LINES
- EXISTING RIGHT-OF-WAY
- UTILITY EASEMENT
- UTILITY EASEMENT

PREPARED BY:  
CITY OF CHARLOTTE  
ENGINEERING & PROPERTY MANAGEMENT  
600 EAST FOURTH STREET  
CHARLOTTE, NC 28202  
704-336-2291

CHARLOTTE ENGINEERING & PROPERTY MANAGEMENT		
REVISIONS	BRYANT PARK PLAN	JOB NO. 512-09-038
		FILE NO. 067-021-12
	PROPERTY ACQUISITION OWNERS: LEWIS H. PARHAM JR. AND WIFE ELIZABETH H. PARHAM AND W. HUGO HEIDENREICH AND WIFE MARGARET S. HEIDENREICH CHARLOTTE, MECKLENBURG CO., NC	SHEET 1
DRAWN BY LG		OF 2
DATE	CHECKED BY DHS SURVEY SUPVR. <i>DHS</i>	
K: \AUTOCAD\EN_SU-LD4\209038\PLATS\PARCEL 19.DWG		

ACQUISITION BY DB 26373 PG 151

26373-151

I, DAVID H. SNIDER, CERTIFY THAT THIS PLAT WAS PREPARED UNDER MY SUPERVISION AND THAT THE PLAT WAS PREPARED FOR THE PURPOSE OF ACQUISITION AND EASEMENTS ONLY, AND IS NOT INTENDED TO BE A BOUNDARY SURVEY OF PROPERTY SHOWN.

*David H. Snider* 8/2/2010  
 DAVID H. SNIDER, NC P.L.S. L-2942 DATE

STATE OF NORTH CAROLINA  
 COUNTY OF MECKLENBURG

REVIEW OFFICER OF MECKLENBURG COUNTY,  
 CERTIFY THAT THE MAP OR PLAT TO WHICH THIS CERTIFICATION IS  
 AFFIXED MEETS ALL STATUTORY REQUIREMENTS FOR RECORDING.

REVIEW OFFICER \_\_\_\_\_ DATE \_\_\_\_\_

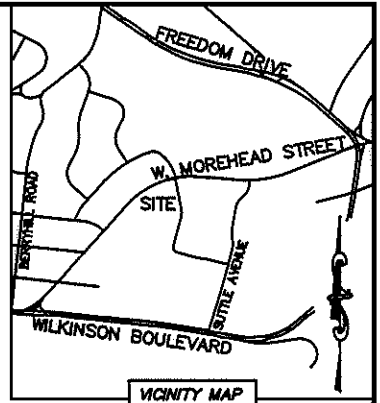
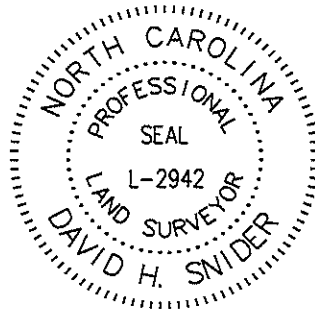

VICINITY MAP  
 (not to scale)

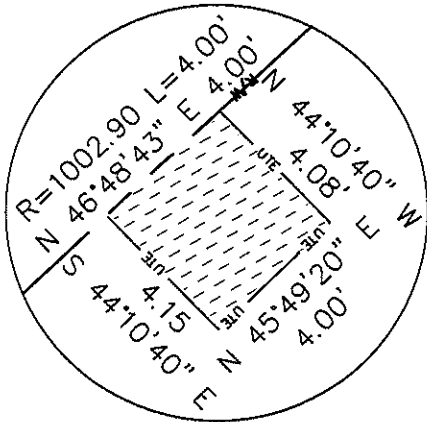

DETAIL A:  
 (NOT TO SCALE)

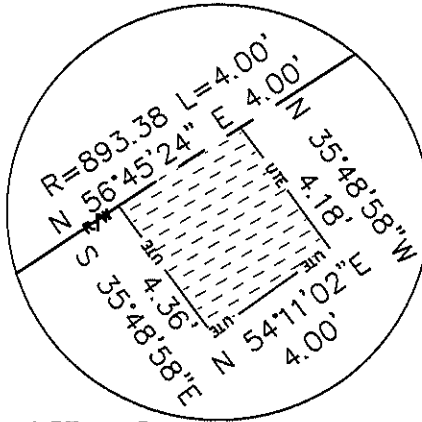

DETAIL B:  
 (NOT TO SCALE)

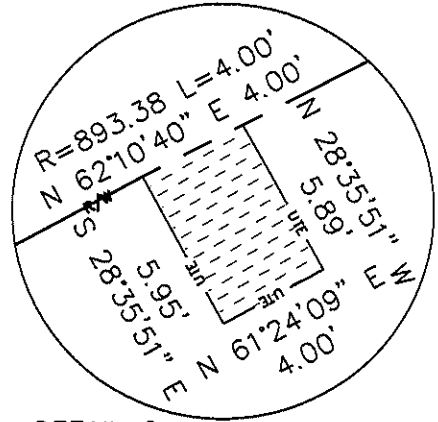

DETAIL C:  
 (NOT TO SCALE)

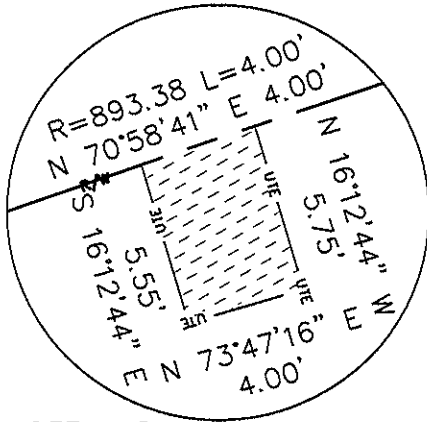

DETAIL D:  
 (NOT TO SCALE)

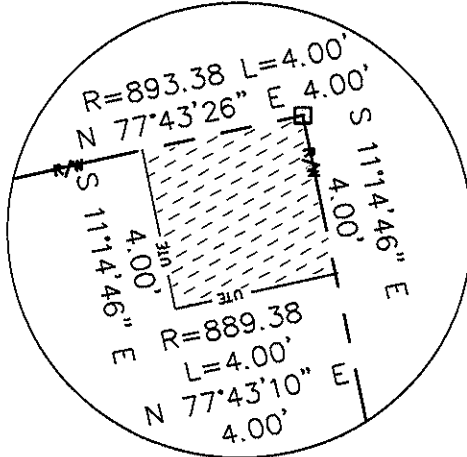

DETAIL E:  
 (NOT TO SCALE)



LINE TABLE		
LINE	LENGTH	BEARING
(L1)	(50.00')	(N 79°00'00" E)
L2	50.00'	N 78°41'38" E
(L3)	(165.00')	(S 15°40'10" W)
L4	165.00'	S 15°21'48" W
(L5)	(120.51')	(N 31°50'40" W)
L6	120.25'	N 32°09'02" W
(L7)	(42.57')	(S 63°44'09" W)
L8	42.49'	S 63°25'47" W

CURVE TABLE		
CURVE	RADIUS & ARC	CHORD
C1	R=1002.90 L=92.82'	N 44°02'47" E 92.79'
C2	R=1002.90 L=35.87'	N 47°57'04" E 35.87'
C3	R=893.38 L=119.40'	N 52°47'58" E 119.31'
C4	R=893.38 L=80.53'	N 59°28'03" E 80.50'
C5	R=893.38 L=133.21'	N 66°34'40" E 133.09'
C6	R=893.38 L=101.18'	N 74°21'04" E 101.13'

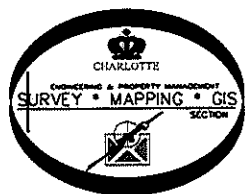

LEGEND

- REBAR OR IRON PIN FOUND
- COMPUTED POINT
- PROPERTY LINES
- EXISTING RIGHT-OF-WAY
- UTILITY EASEMENT
- UTILITY EASEMENT

PREPARED BY:  
 CITY OF CHARLOTTE  
 ENGINEERING & PROPERTY MANAGEMENT  
 600 EAST FOURTH STREET  
 CHARLOTTE, NC 28202  
 704-336-2291

CHARLOTTE ENGINEERING & PROPERTY MANAGEMENT		
REVISIONS	BRYANT PARK PLAN	JOB NO. 512-09-038
		FILE NO. 067-021-12
	PROPERTY ACQUISITION OWNERS: LEWIS H. PARHAM JR. AND WIFE ELIZABETH H. PARHAM AND W. HUGO HEIDENREICH AND WIFE MARGARET S. HEIDENREICH CHARLOTTE, MECKLENBURG CO., NC	SHEET 2
DRAWN BY LG	CHECKED BY DHS SURVEY SUPR. <i>SNK</i>	OF 2
DATE	K:\AUTOCAD\EN_SU-LD4\209038\PLATS\PARCEL 19.DWG	