

I, JAMES E. DAVIS, CERTIFY THAT THIS PLAT WAS PREPARED UNDER MY SUPERVISION AND THAT THE PLAT WAS PREPARED FOR THE PURPOSE OF ACQUISITION AND EASEMENTS ONLY, AND IS NOT INTENDED TO BE A BOUNDARY SURVEY OF PROPERTY SHOWN.

[Signature]
 JAMES E. DAVIS, NC P.L.S. L-3747 DATE

State of North Carolina
 County of Mecklenburg

I, _____, Review Officer of Mecklenburg County, certify that the map or plat to which this certification is affixed meets all statutory requirements for recording.

Review Officer _____

Date _____

- NOTE:**
- HORIZONTAL DATUM FOR PROJECT IS NC GRID NAD83(2011) AND VERTICAL DATUM IS NAVD88 FROM GPS OBSERVATIONS COMPLETED ON APRIL 04, 2017 UTILIZING THE NC VRS NETWORK. NCGS POINT "NC77" WAS UTILIZED AS THE NETWORK BASE AND NGS GEOD 12B WAS THE GEOD MODEL. THE LOCALIZATION POINT FOR THE PROJECT WAS MERRICK #205 HAVING NC GRID COORDINATES OF N=549229.675 FEET, E=1443216.005 FEET, ELEVATION=695.98 FEET AND A COMBINED FACTOR OF 0.999844756.
 - ALL DISTANCES SHOWN ARE HORIZONTAL GROUND DISTANCES.
 - AREAS DETERMINED BY COORDINATE COMPUTATIONS.
 - TRAVERSE ADJUSTED BY LEAST SQUARE ADJUSTMENT METHOD.

Parcel Line Table

Line #	Length	Direction
L1	67.75	S81° 43' 25"W
L2	177.92	S7° 27' 44"E
L3	7.00	S7° 27' 42"E
L4	5.08	S7° 27' 42"E
L5	67.75	N81° 43' 25"E
L6	9.24	S7° 27' 44"E
L7	180.76	S7° 27' 44"E
L8	11.70	S78° 01' 37"E
L9	48.00	N81° 59' 24"E
L10	9.22	N32° 35' 28"E
L11	2.40	N81° 59' 24"E
L12	8.33	N81° 59' 24"E
L13	50.64	S2° 40' 47"W

LEGEND

- COMPUTED POINT
- IRON PIN FOUND
- PROPERTY LINE
- TEMP. CONSTRUCTION EASEMENT
- SIDEWALK UTILITY EASEMENT

- AREAS:**
- TOTAL AREA 12,870 SQ. FT.
 - TEMP. CONSTRUCTION EASEMENT 38 SQ. FT.
 - SIDEWALK UTILITY EASEMENT 378 SQ. FT.
 - AREA REMAINING 12,870 SQ. FT.

PREPARED BY:
 MERRICK & COMPANY
 1001 MOREHEAD SQUARE DR.
 SUITE 530
 CHARLOTTE, NC 28203
 704-529-6500



DB 33105-830

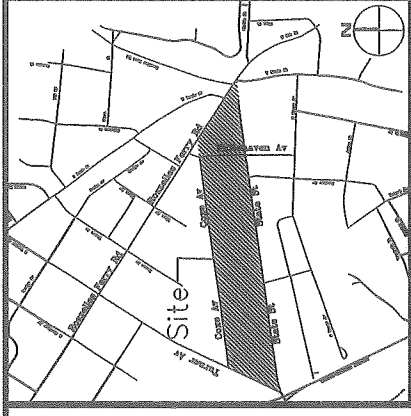

VICINITY MAP (NOT TO SCALE)

ALLEY WAY - 10' R/W
 (MB: 50 PG: 837)

NC GRID
 N: 548044.1329
 E: 1443206.1345



071-105-07
 NOW OR FORMERLY
 HFC CHARLOTTE
 APARTMENTS LLC
 426 STATE ST
 DB 29136 PG 885
 PB 230 PG 149

071-105-08
 NOW OR FORMERLY
 HFC CHARLOTTE
 APARTMENTS LLC
 422 STATE ST
 DB 29136 PG 885
 PB 230 PG 149

071-105-06
 NOW OR FORMERLY
 NATHANIEL E JONES JR
 430 STATE ST
 DB 31306 PG 334
 PB 230 PG 210

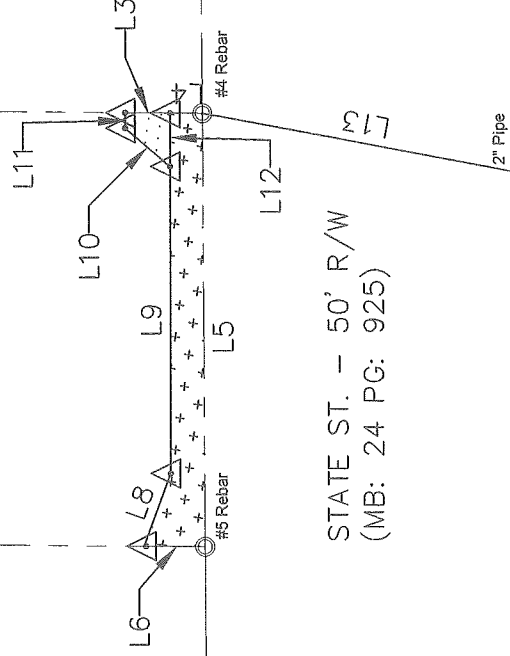

STATE ST. - 50' R/W
 (MB: 24 PG: 925)

CHARLOTTE
 ENGINEERING & PROPERTY MANAGEMENT

**STATE STREET
 PEDESTRIAN
 IMPROVEMENT PROJECT**

PROPERTY ACQUISITION
 OWNER: HFC CHARLOTTE
 APARTMENTS LLC
 CHARLOTTE, MECKLENBURG CO., NC

REVISIONS

SCALE 1" = 30'

DRAWN BY: RRH

DATE 04/17/2018

CHECKED BY _____

SURVEY SUPVR. _____

JOB NO. PMS161539

FILE NO. _____

SHEET 1 OF 1