

I, JACKIE W. BRIM, CERTIFY THAT THIS PLAT WAS PREPARED UNDER MY SUPERVISION AND THAT THE PLAT WAS PREPARED FOR THE PURPOSE OF ACQUISITION AND EASEMENTS ONLY, AND IS NOT INTENDED TO BE A BOUNDARY SURVEY OF PROPERTY SHOWN.

Jackie W. Brim 3-28-2018
 JACKIE W. BRIM, NC P.L.S. L-4348 DATE

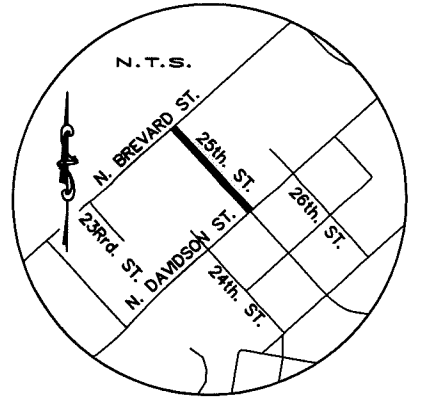
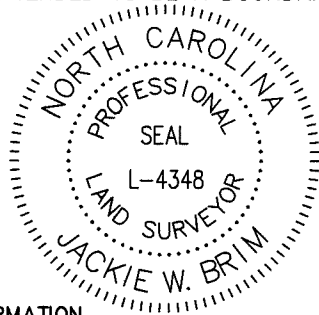

NOTES:

- 1.) BEARINGS AND DISTANCES SHOWN IN PARENTHESES ARE BASED ON RECORDED MAP INFORMATION
- 2.) COMPUTED PROJECT DISTANCE _____*
- 3.) TOTAL AREA 50,729 SQ. FT.
- 4.) TEMP. CONSTRUCTION EASEMENT 2,951 SQ. FT.
- 5.) SIDEWALK/UTILITY/GAS LINE EASEMENT 1,556 SQ. FT.
- 6.) PERMANENT UTILITY EASEMENT 439 SQ. FT.
- 7.) FEE SIMPLE OUTSIDE EXISTING R/W 1,464 SQ. FT.
- 8.) AREA REMAINING 49,265 SQ. FT.



CITY OF CHARLOTTE
 TAX CODE: 083-053-15
 DB 28101 PG 166
 NO ADDRESS GIVEN

TROLLEYS INVESTMENTS, LLC
 TAX CODE: 083-053-10
 DB 22780 PG 217
 2221 N. DAVIDSON STREET

LEGEND

- #4 REBAR SET OR PK NAIL
- IRON PIN FOUND
- CALCULATED POINT
- LINES SURVEYED
- LINES NOT SURVEYED
- TEMP. CONSTRUCTION EASEMENT (e)
- SIDEWALK/UTILITY/GAS LINE EASEMENT (SUGLE)
- PERMANENT UTILITY EASEMENT (PUE)
- FEE SIMPLE OUTSIDE EXISTING R/W

#4 rebar
 COMBINED GRID
 FACTOR=0.99984438
 N.547219.71
 E.1457800.28

FLORIDA CARBONIC MANUFACTURING COMPANY
 TAX CODE: 083-053-09
 DB 3372 PG 043
 2201 N. DAVIDSON STREET



NC GRID NAD 83(2011)

SEE SHEET 2 OF 2
 FOR DETAILS

N. DAVIDSON STREET
 RIGHT-OF-WAY VARIES

PREPARED BY:
 CITY OF CHARLOTTE
 ENGINEERING & PROPERTY
 MANAGEMENT DEPT.
 600 EAST FOURTH STREET
 CHARLOTTE, NC 28202
 704-336-2291

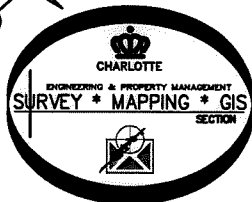

		JOB NO. 512-14-005
25 th. STREET CONNECTION		214005
PROPERTY OF FLORIDA CARBONIC MANUFACTURING COMPANY TAX CODE: 083-053-09 CHARLOTTE, MECKLENBURG CO., NC		SHEET 1
DRAWN BY G.F. CHECKED BY JWB SURVEY SUPVR.		OF 3
K:\AutoCad\En_su-LD4\214005\PLAT MAPS\Plat-8 revised 09-20-17		

DB 32967-949

I, JACKIE W. BRIM, CERTIFY THAT THIS PLAT WAS PREPARED UNDER MY SUPERVISION AND THAT THE PLAT WAS PREPARED FOR THE PURPOSE OF ACQUISITION AND EASEMENTS ONLY, AND IS NOT INTENDED TO BE A BOUNDARY SURVEY OF PROPERTY SHOWN.

Jackie W. Brim 3-28-2018
 JACKIE W. BRIM, NC P.L.S. L-4348 DATE

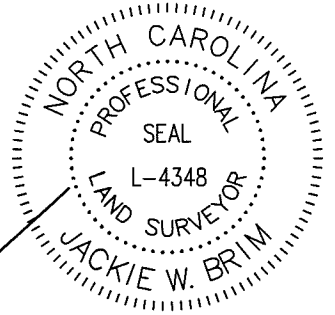

STATE OF NORTH CAROLINA
 COUNTY OF MECKLENBURG

I, _____, REVIEW OFFICER OF MECKLENBURG COUNTY, CERTIFY THAT THE MAP OR PLAT TO WHICH THIS CERTIFICATION IS AFFIXED MEETS ALL STATUTORY REQUIREMENTS FOR RECORDING.

REVIEW OFFICER _____ DATE _____

SEE DETAIL "A"

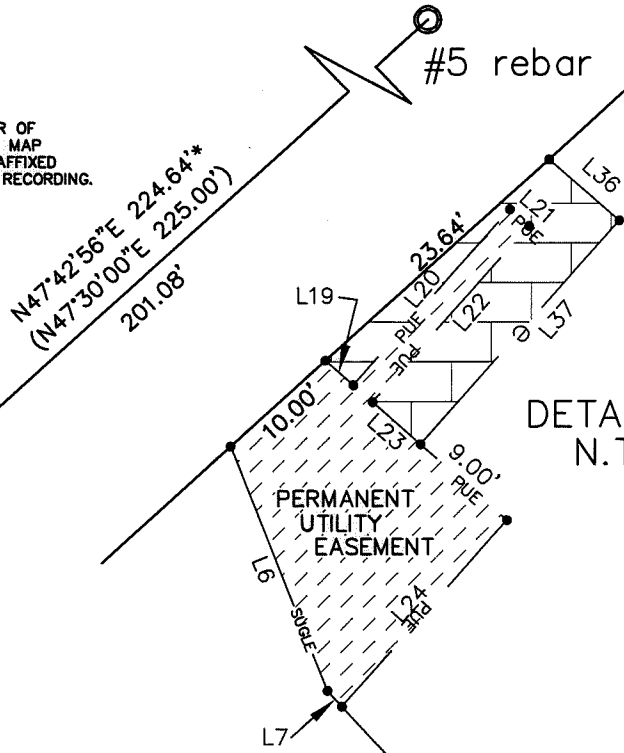
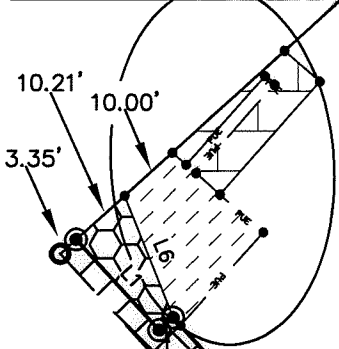

DETAIL "A"
 N.T.S.

FLORIDA CARBONIC MANUFACTURING COMPANY
 TAX CODE: 083-053-09
 DB 3372 PG 043
 2201 N. DAVIDSON STREET



PERMANENT UTILITY EASEMENT

DETAIL "B"
 N.T.S.

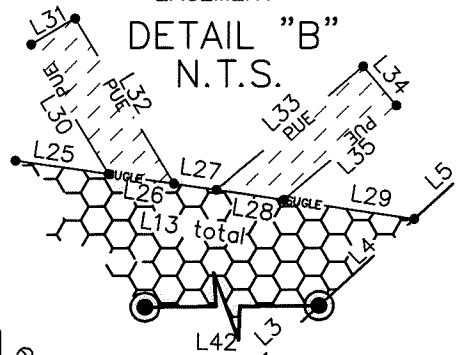

25TH STREET
 RIGHT-OF-WAY VARIES



NC GRID NAD 83(2011)

old property line

new property line

SEE DETAIL "B"

SEE LINE TABLE
 SHEET 2 OF 3

PREPARED BY:
 CITY OF CHARLOTTE
 ENGINEERING & PROPERTY
 MANAGEMENT DEPT.
 600 EAST FOURTH STREET
 CHARLOTTE, NC 28202
 704-336-2291

CHARLOTTE ENGINEERING & PROPERTY MANAGEMENT DEPT.		
REVISIONS 3. added tag label 3-28-18 2. revised R/W & SINGLE revised TCE area 9-20-17 1. revised line type to SINGLE in DETAIL A & B. 8-07-17	25 th. STREET CONNECTION	JOB NO. 512-14-005 214005
SCALE 1" = 30' 	PROPERTY OF FLORIDA CARBONIC MANUFACTURING COMPANY TAX CODE: 083-053-09 CHARLOTTE, MECKLENBURG CO., NC	SHEET 2 OF 3
DRAWN BY G.F. DATE _____	CHECKED BY JWB SURVEY SUPVR.	
K:\AutoCad\En_su-LD4\214005\PLAT MAPS\Plat-8 revised 09-20-17		

DB 32967-949

I, JACKIE W. BRIM, CERTIFY THAT THIS PLAT WAS PREPARED UNDER MY SUPERVISION AND THAT THE PLAT WAS PREPARED FOR THE PURPOSE OF ACQUISITION AND EASEMENTS ONLY, AND IS NOT INTENDED TO BE A BOUNDARY SURVEY OF PROPERTY SHOWN.

Jackie W. Brim 3-28-2018
 JACKIE W. BRIM, NC P.L.S. L-4348 DATE

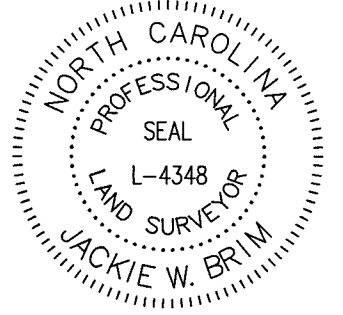

Line Table		
Line #	Length	Direction
L1	19.26	S42°12'19"E
L2	2.93	N47°47'41"E
L3	23.36	S47°43'02"W
L4	13.69	S47°43'02"W
L5	16.80	S47°43'02"W
L6	20.61	S21°30'28"E
L7	1.67	S42°12'28"E
L8	29.75	S42°12'28"E
L9	3.87	S73°17'13"E
L10	46.20	S42°12'19"E
L11	36.98	S56°24'14"E
L12	64.93	S42°12'19"E
L13	31.48	S81°34'17"E
L14	20.57	N89°00'51"E
L15	58.58	S45°20'03"E
L16	20.60	S82°09'31"E
L17	67.75	S42°12'19"E
L18	3.17	S82°09'31"E
L19	2.92	S48°33'39"E
L20	18.50	N41°24'55"E

Line Table		
L21	2.00	S48°35'05"E
L22	18.50	S41°24'55"W
L23	5.00	S48°33'39"E
L24	19.49	S41°26'21"W
L25	7.37	S81°34'17"E
L26	5.16	S81°34'17"E
L27	3.36	S81°34'17"E
L28	5.33	S81°34'17"E
L29	10.27	S81°34'17"E
L30	11.82	N30°45'05"W
L31	4.00	N59°14'55"E
L32	15.08	S30°45'05"E
L33	15.00	N49°47'28"E
L34	4.00	S40°12'32"E
L35	11.47	S49°47'28"W
L36	7.32	S48°35'05"E
L37	23.50	S41°24'55"W
L38	7.37	N49°47'28"E
L39	8.21	S40°12'32"E
L40	10.61	S82°09'31"E

Line Table		
L41	190.61	S42°12'28"E
L42	23.23	N89°31'51"E

PREPARED BY:
 CITY OF CHARLOTTE
 ENGINEERING & PROPERTY
 MANAGEMENT DEPT.
 600 EAST FOURTH STREET
 CHARLOTTE, NC 28202
 704-336-2291

		CHARLOTTE ENGINEERING & PROPERTY MANAGEMENT DEPT.
REVISIONS 3. added tag label 3-28-18 2. revised R/W & SUGLE revised TCE area 9-20-17 1. revised line type to SUGLE in DETAIL A & B 8-07-17	25 th. STREET CONNECTION	JOB NO. 512-14-005 214005
SCALE 1" = 30' 	PROPERTY OF FLORIDA CARBONIC MANUFACTURING COMPANY TAX CODE: 083-053-09 CHARLOTTE, MECKLENBURG CO., NC	SHEET 3 OF 3
DRAWN BY G.F. DATE	CHECKED BY JWB SURVEY SUPVR.	
K:\AutoCad\En_su-LD4\214005\PLAT MAPS\Plat-8 revised 09-20-17		

DB 32967-949