

VICINITY
N.T.S.

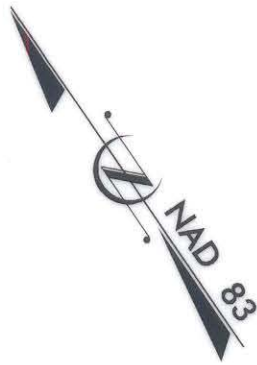

MYRA D. PETTY
804 NORRIS AVE.
DB 6526 PG 161
TAX *08504207



EVCO CONSTRUCTION CO.
2700 N. GRAHAM ST.
DB 4203 PG 293
TAX *08504205

ACQUISITION BY CITY
RECORDED IN DEED BOOK
12832-512
DATE 11/5/2001

15

MYRTLE D. HOOPER
808 NORRIS AVE.
DB 2711 PG 90
TAX #08504206

I, MARK FUNKHOUSER, CERTIFY THAT THIS PLAT WAS PREPARED UNDER MY SUPERVISION AND THAT THE PLAT WAS PREPARED FOR THE PURPOSE OF ACQUISITION AND EASEMENTS ONLY, AND IS NOT INTENDED TO BE A BOUNDARY SURVEY OF PROPERTY SHOWN

MEF 8-6-01

LINE	DIRECTION	DISTANCE
L1	N 54° 53' 59" W	61.48 FT.
L2	N 32° 08' 46" E	3.38 FT.
L3	N 32° 08' 46" E	28.14 FT.
L4	S 36° 33' 26" E	16.38 FT.
L5	S 3° 36' 48" W	15.52 FT.
L6	S 57° 01' 07" E	38.72 FT.
L7	S 32° 08' 46" W	11.96 FT.
L8	S 32° 08' 46" W	2.58 FT.
L9	S 54° 12' 06" E	61.52 FT.

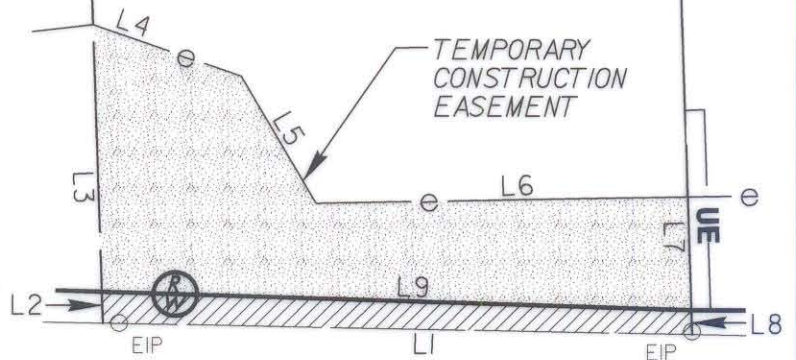

NORRIS AVENUE

AREA FROM DEED OR TAX OFFICE	AREA ACQUIRED	RECORD AREA LESS AREA ACQUIRED	TEMPORARY CONSTRUCTION AREA
8,146 SQ. FT. 0.187 ACRE	181 SQ. FT. 0.004 ACRE	7,965 SQ. FT. 0.183 ACRE	942 SQ. FT. 0.022 ACRE



LEGEND

- EXISTING IRON PIN
- SET IRON PIN
- NEW PROPERTY LINE
- AREA ACQUIRED
- TEMPORARY CONSTRUCTION EASEMENT

PBS&J Plans Prepared By
200 EAST WOODLAWN ROAD, SUITE 310
CHARLOTTE, NORTH CAROLINA 28217

CHARLOTTE ENGINEERING AND PROPERTY MANAGEMENT		JOB NO. 512-00-072
REVISIONS	GRAHAM STREET AT NORRIS AVENUE INTERSECTION IMPROVEMENT PROJECT	FILE NO. PLAT 15
DRAWN BY: VTS		SHEET 1
CHECKED BY: MED	PROPERTY ACQUISITION MYRTLE D. HOOPER	OF
SURVEY SUPVR.	CHARLOTTE, MECKLENBURG CO., NC	1
	DATE: 8/02/01 SCALE: 1"=20'	