

VICINITY
N.T.S.

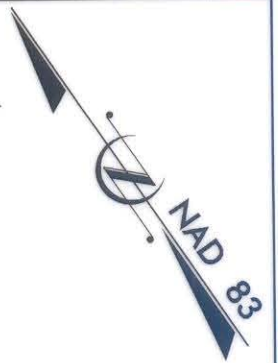

ACQUISITION BY CITY
RECORDED IN DEED BOOK
12852 - 520
DATE **11/5/2001**

17

MYRA D. PETTY
804 NORRIS AVE.
DB 6526 PG 161
TAX #08504207

MYRTLE D. HOOPER
808 NORRIS AVE.
DB 2711 PG 90
TAX #08504206

RUBY MAE HARRELL
800 NORRIS AVE.
DB 2966 PG 587
TAX #08504208

LINE	DIRECTION	DISTANCE
L1	N 54° 53' 57" W	60.10 FT.
L2	N 32° 08' 46" E	2.58 FT.
L3	N 32° 08' 46" E	11.96 FT.
L4	S 57° 01' 08" E	60.00 FT.
L5	S 32° 02' 07" W	13.13 FT.
L6	S 32° 02' 07" W	3.63 FT.
L7	S 55° 54' 11" E	60.05 FT.

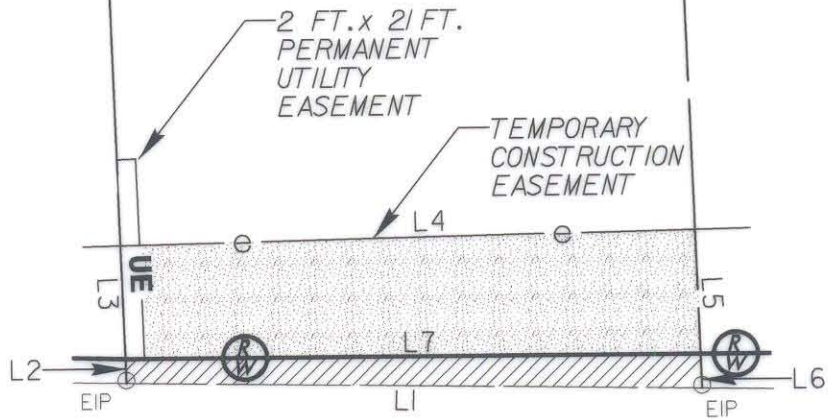

NORRIS AVENUE

I, MARK FUNKHOUSER, CERTIFY THAT THIS PLAT WAS PREPARED UNDER MY SUPERVISION AND THAT THE PLAT WAS PREPARED FOR THE PURPOSE OF ACQUISITION AND EASEMENTS ONLY, AND IS NOT INTENDED TO BE A BOUNDARY SURVEY OF PROPERTY SHOWN

Mark E. Funkhouser 7-16-01



AREA FROM DEED OR TAX OFFICE	AREA ACQUIRED	RECORD AREA LESS AREA ACQUIRED	TEMPORARY CONSTRUCTION AREA	PERMANENT UTILITY EASEMENT
8,320 SQ. FT. 0.191 ACRE	187 SQ. FT. 0.004 ACRE	8,133 SQ. FT. 0.187 ACRE	729 SQ. FT. 0.017 ACRE	42 SQ. FT.



LEGEND

- EXISTING IRON PIN
- SET IRON PIN
- NEW PROPERTY LINE
- AREA ACQUIRED
- TEMPORARY CONSTRUCTION EASEMENT

PBSJ Plans Prepared By
200 EAST WOODLAWN ROAD, SUITE 310
CHARLOTTE, NORTH CAROLINA 28217

REVISIONS	GRAHAM STREET AT NORRIS AVENUE INTERSECTION IMPROVEMENT PROJECT	JOB NO. 512-00-072
		FILE NO. PLAT 17
	PROPERTY ACQUISITION MYRA D. PETTY	SHEET 1
DRAWN BY: VTS	CHARLOTTE, MECKLENBURG CO., NC	OF
CHECKED BY: MED	DATE: 7/16/01	SCALE: 1"=20'
SURVEY SUPVR.		1