

I, DAVID H. SNIDER, CERTIFY THAT THIS PLAT WAS PREPARED UNDER MY SUPERVISION AND THAT THE PLAT WAS PREPARED FOR THE PURPOSE OF ACQUISITION AND EASEMENTS ONLY, AND IS NOT INTENDED TO BE A BOUNDARY SURVEY OF PROPERTY SHOWN.

David H. Snider 1/7/13
 DAVID H. SNIDER, NC P.L.S. L-2942 DATE

STATE OF NORTH CAROLINA
 COUNTY OF MECKLENBURG

I, _____ REVIEW OFFICER OF MECKLENBURG COUNTY, CERTIFY THAT THE MAP OR PLAT TO WHICH THIS CERTIFICATION IS AFFIXED MEETS ALL STATUTORY REQUIREMENTS FOR RECORDING.

REVIEW OFFICER _____ DATE _____

NOTE:

- 1) BEARINGS AND DISTANCE SHOWN IN PARENTHESIS ARE BASED ON RECORDED INFORMATION.
- 2) COMPUTED PROJECT DISTANCE - *
- 3) TOTAL AREA 52,262 SQ.FT.
- 4) TEMP. CONSTRUCTION EASEMENT 328 SQ.FT.
- 5) PERMANENT SHELTER EASEMENT 362 SQ.FT.
- 6) TOTAL AREA REMAINING 52,262 SQ.FT.

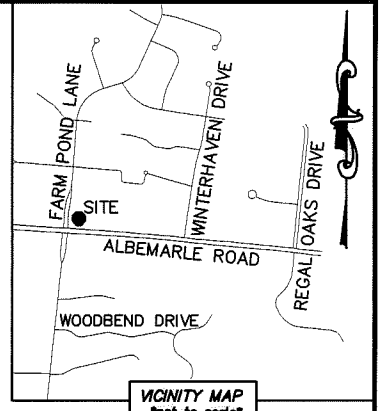
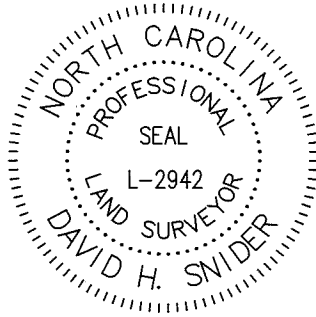

VICINITY MAP
 not to scale

LINE TABLE		
LINE	LENGTH	BEARING
L1	15.32'	N 03°45'48" E
L2	10.38'	N 03°45'48" E
L3	15.29'	S 03°45'48" W
L4	10.30'	S 03°45'48" W



10316101
 NRG-FOUR SEASONS LLC
 DB 24244/PG 103
 6321,6339,6437 & 6455
 ALBEMARLE ROAD

FARM POND LANE
 (VARIABLE PUBLIC R/W)

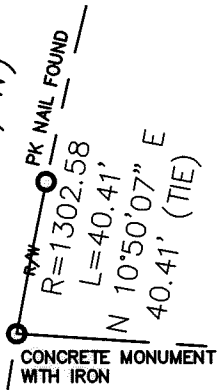

(S 86°14'56" E 256.12')
 S 86°15'17" E 256.31'

10316107
 McDONALD'S REAL ESTATE COMPANY
 DB 25714/PG 64
 6301 ALBEMARLE ROAD

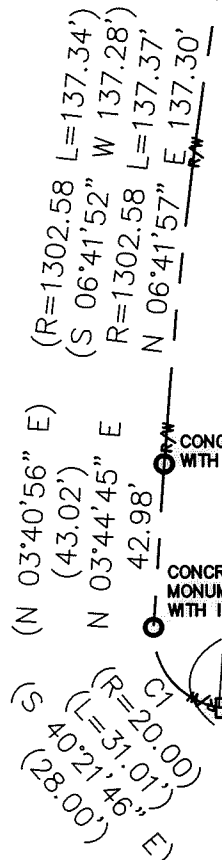

DETAIL: (NOT TO SCALE)

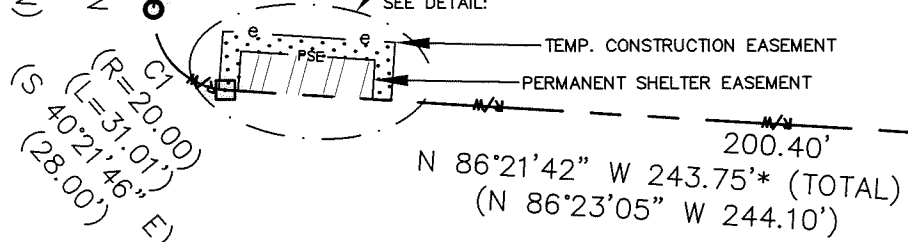
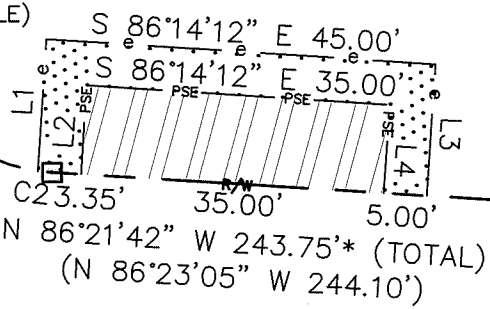

ALBEMARLE ROAD
 (VARIABLE PUBLIC R/W)

LEGEND

- REBAR OR IRON PIN FOUND
- COMPUTED POINT
- PROPERTY LINES
- EXISTING RIGHT-OF-WAY
- TEMP. CONSTRUCTION EASEMENT
- PERMANENT SHELTER EASEMENT
- TEMP. CONSTRUCTION EASEMENT
- PERMANENT SHELTER EASEMENT

PREPARED BY:
 CITY OF CHARLOTTE
 ENGINEERING & PROPERTY MANAGEMENT
 600 EAST FOURTH STREET
 CHARLOTTE, NC 28202
 704-336-2291

CURVE TABLE		
CURVE	RADIUS & ARC	CHORD
C1	R=20.00 L=29.76'	N 38°54'19" W 27.09'
C2	R=20.00 L=1.65'	N 83°53'37" W 1.65'

CHARLOTTE ENGINEERING & PROPERTY MANAGEMENT		
REVISIONS	FY13 BUS STOPS ALBEMARLE RD. AT FARM POND LN.	JOB NO. 512-12-049
		FILE NO. 103-161-07
PROPERTY ACQUISITION OWNER: McDONALD'S REAL ESTATE COMPANY CHARLOTTE, MECKLENBURG CO., NC		SHEET 1
SCALE 1"=50'	DRAWN BY LG	OF 1
DATE	CHECKED BY DHS SURVEY SUPVR. <i>DNR</i>	
K:\AUTOCAD\EN_SU-LD4\212049\FARMPONDALBEMARLE\DWG		

DB 30343-995