

I, DAVID H. SNIDER, CERTIFY THAT THIS PLAT WAS PREPARED UNDER MY SUPERVISION AND THAT THE PLAT WAS PREPARED FOR THE PURPOSE OF ACQUISITION AND EASEMENTS ONLY, AND IS NOT INTENDED TO BE A BOUNDARY SURVEY OF PROPERTY SHOWN.

DAVID H. SNIDER, NC P.L.S. L-2942 DATE

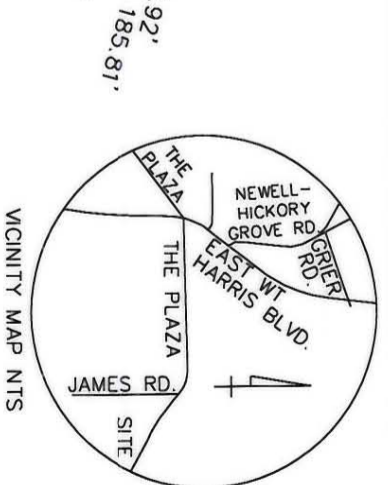
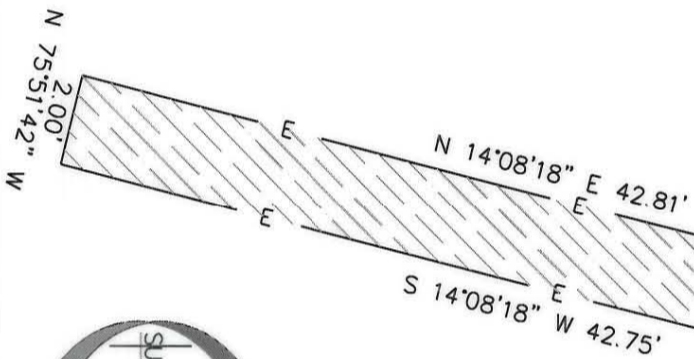
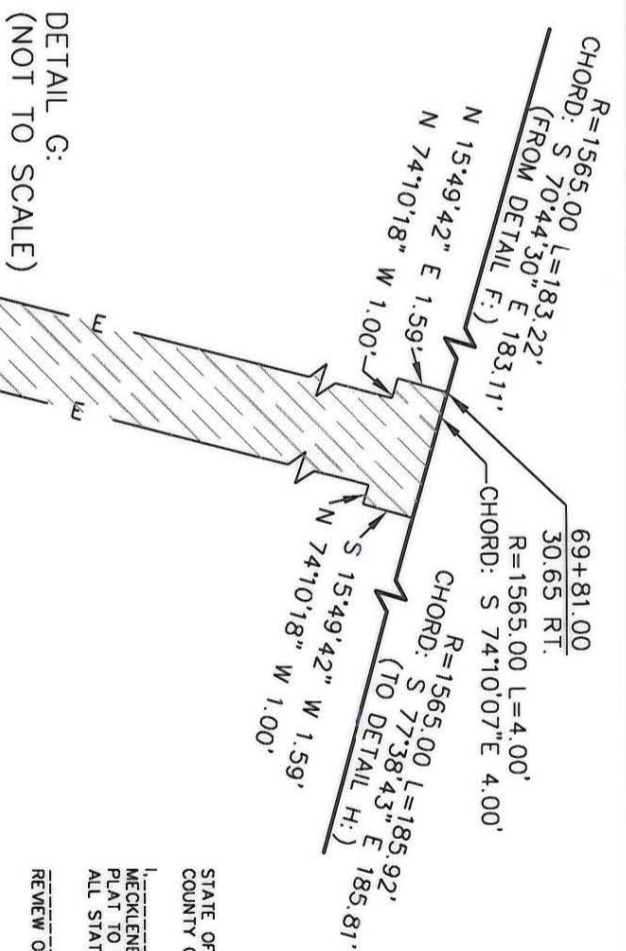
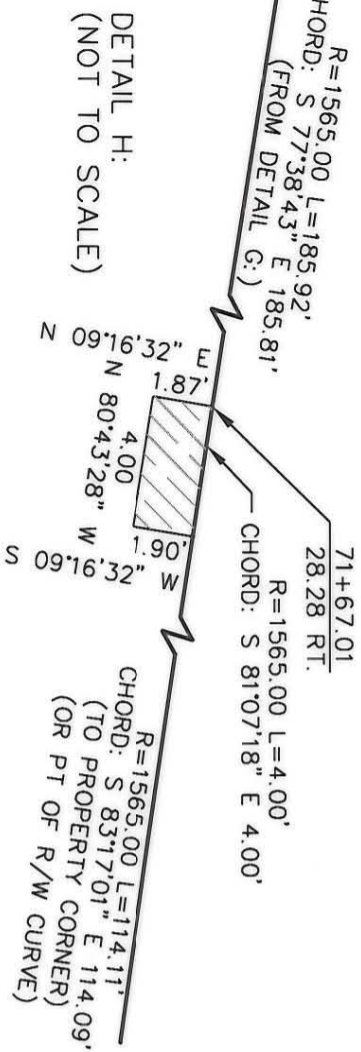
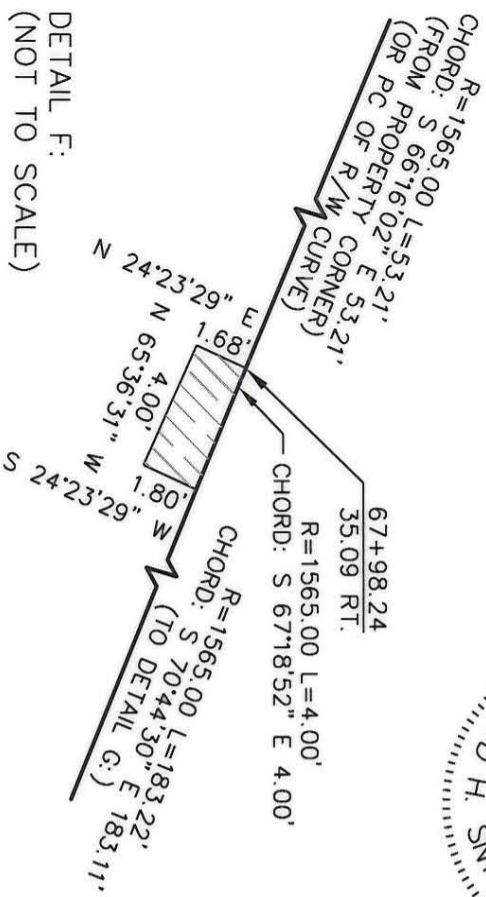
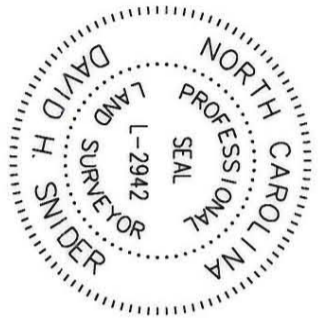

STATE OF NORTH CAROLINA
COUNTY OF MECKLENBURG

REVIEW OFFICER OF MECKLENBURG COUNTY, CERTIFY THAT THE MAP OR PLAT TO WHICH THIS CERTIFICATION IS AFFIXED MEETS ALL STATUTORY REQUIREMENTS FOR RECORDING.

REVIEW OFFICER _____ DATE _____

LEGEND

IRON PIN FOUND ○

UTILITY EASEMENT ▨

ACQUISITION BY CITY
RECORDED IN DEED BOOK

20675-66
DATE 06-30-06

NOTE: BEARINGS AND DISTANCES SHOWN IN PARENTHESES ARE BASED ON RECORDED MAP INFORMATION.

CHARLOTTE ENGINEERING DEPARTMENT

THE PLAZA STREETSCAPE
EASEMENT ACQUISITION

OWNER: PLAZA ROAD LLC
CHARLOTTE, MECKLENBURG CO., NC

REVISIONS		JOB NO.
THE PLAZA STREETSCAPE		512-00-067
EASEMENT ACQUISITION		FILE NO.
OWNER: PLAZA ROAD LLC		107-201-05
CHARLOTTE, MECKLENBURG CO., NC		SHEET
DRAWN BY: LG		4
CHECKED BY: DHS		OF
DATE: 03-16-2006		5
PROJECT LOCATION: K:\AUTOCAD\EN_SU_ID4\200667\DWG\107-201-05.DWG		

PREPARED BY:
CITY OF CHARLOTTE
ENGINEERING & PROPERTY MANAGEMENT
600 EAST FOURTH STREET
CHARLOTTE, NC 28202
704-336-2291

