

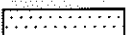

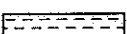
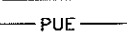
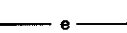

I, _____ REVIEW OFFICER OF MECKLENBURG COUNTY, CERTIFY THAT THE MAP OR PLAT TO WHICH THIS CERTIFICATION IS AFFIXED MEETS ALL STATUTORY REQUIREMENTS OF NORTH CAROLINA GENERAL STATUTES FOR RECORDING.

REVIEW OFFICER _____ DATE _____

LEGEND

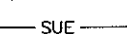
TCE = TEMPORARY CONSTRUCTION EASEMENT
 SUE = PERMANENT SIDEWALK AND UTILITY EASEMENT
 PUE = PERMANENT UTILITY EASEMENT

-  = PUE
-  = TCE
-  = SUE
-  = PUE
-  = TCE
-  = EXISTING R/W
-  = SUE
-  = IRON PIN FOUND

NOTE:

- 1) BEARINGS AND DISTANCES SHOWN IN PARENTHESES ARE BASED ON RECORDED MAP OR DEED INFORMATION.
- 2) TOTAL AREA: 13,438 SF, 0.309 AC
- 3) AREA IN TCE: 862 SF, 0.020 AC
- 4) AREA IN SUE: 214 SF, 0.005 AC
- 5) AREA IN PUE: 7 SF
- 6) FEE AREA REMAINING: 13,438 SF, 0.309 AC



Plans Prepared By:
 5200 77 CENTER DRIVE, SUITE 500
 CHARLOTTE, NORTH CAROLINA 28217
 (704) 522-7275 NCCOA: F-0326

LINE	LENGTH	BEARING
L1	3.44	S73°20'19"W
L2	9.47	S73°20'19"W
L3	33.60	N08°48'19"W
L4	12.15	N65°47'56"W
L5	16.33	N08°24'00"W
L6	8.27	N29°29'22"E
L7	14.65	N84°17'04"E
L8	3.66	N84°17'04"E
L9	3.02	S73°20'19"W
L10	2.37	N17°08'55"W
L11	3.04	N73°34'32"E

CURVE	LENGTH	RADIUS	CHORD BRG	CHORD DIST
C1	60.02	314.07	S11°08'38"E	59.93
C2	58.34	316.50	S11°08'38"E	58.26
C3	2.36	316.50	S16°38'17"E	2.36

NC GRID NAD 83/2007

TAX # 14504415
 REGINALD S. RORIE
 DB 18915, PG 217
 LOT 30, BLK 2
 MB 6, PG 3
 2839 MAYFLOWER ROAD

TAX # 14504416
 R.M. EQUITIES, L.L.C.
 DB 24059, PG 185
 LOT 29, BLK 2
 MB 6, PG 3
 2845 MAYFLOWER ROAD

TAX # 14504417
 BRANCH BANKING AND TRUST COMPANY
 DB 25141, PG 957
 LOT 28, BLK 2
 MB 6, PG 3
 2851 MAYFLOWER ROAD

TAX # 14504418
 GEORGIA F. KENNEDY
 DB 6192, PG 746
 LOT 27, BLK 2
 MB 6, PG 3
 2857 MAYFLOWER ROAD

TAX # 14504433
 MICHAEL I. MYERS AND SOPHIA Z. MYERS
 DB 22082, PG 117
 LOT 12, BLK 2
 MB 6, PG 3
 2816 PHILLIPS AVENUE

TAX # 14504434
 ALFRED CALDWELL JR
 DB 22783, PG 40
 LOT 11, BLK 2
 MB 6, PG 3
 2812 PHILLIPS AVENUE

TAX # 14504432
 TOMMY DELANO REID
 DB 3135, PG 393
 LOT 13, BLK 2
 MB 6, PG 3
 2820 PHILLIPS AVENUE

TAX # 14504520
 CALDONIA W HARDEN AND JOHNNIE MAE HARDEN
 DB 2860, PG 453
 LOT 24, BLK 3
 MB 6, PG 3
 2819 PHILLIPS AVENUE

TAX # 14504521
 VICKIE A EDWARDS
 DB 19328, PG 641
 LOT 23, BLK 3
 MB 6, PG 3
 2827 PHILLIPS AVENUE

I, CHARLES J. DUNBAR, CERTIFY THAT THIS PLAT WAS PREPARED UNDER MY SUPERVISION AND THAT THIS PLAT WAS PREPARED FOR THE PURPOSE OF EASEMENTS ONLY, AND IS NOT INTENDED TO BE A BOUNDARY SURVEY OF PROPERTY SHOWN.

Charles J. Dunbar
 CHARLES J. DUNBAR NC PLS L-4159 DATE 3/29/10

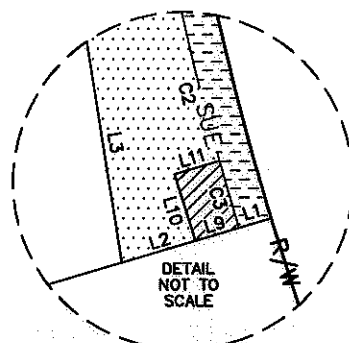
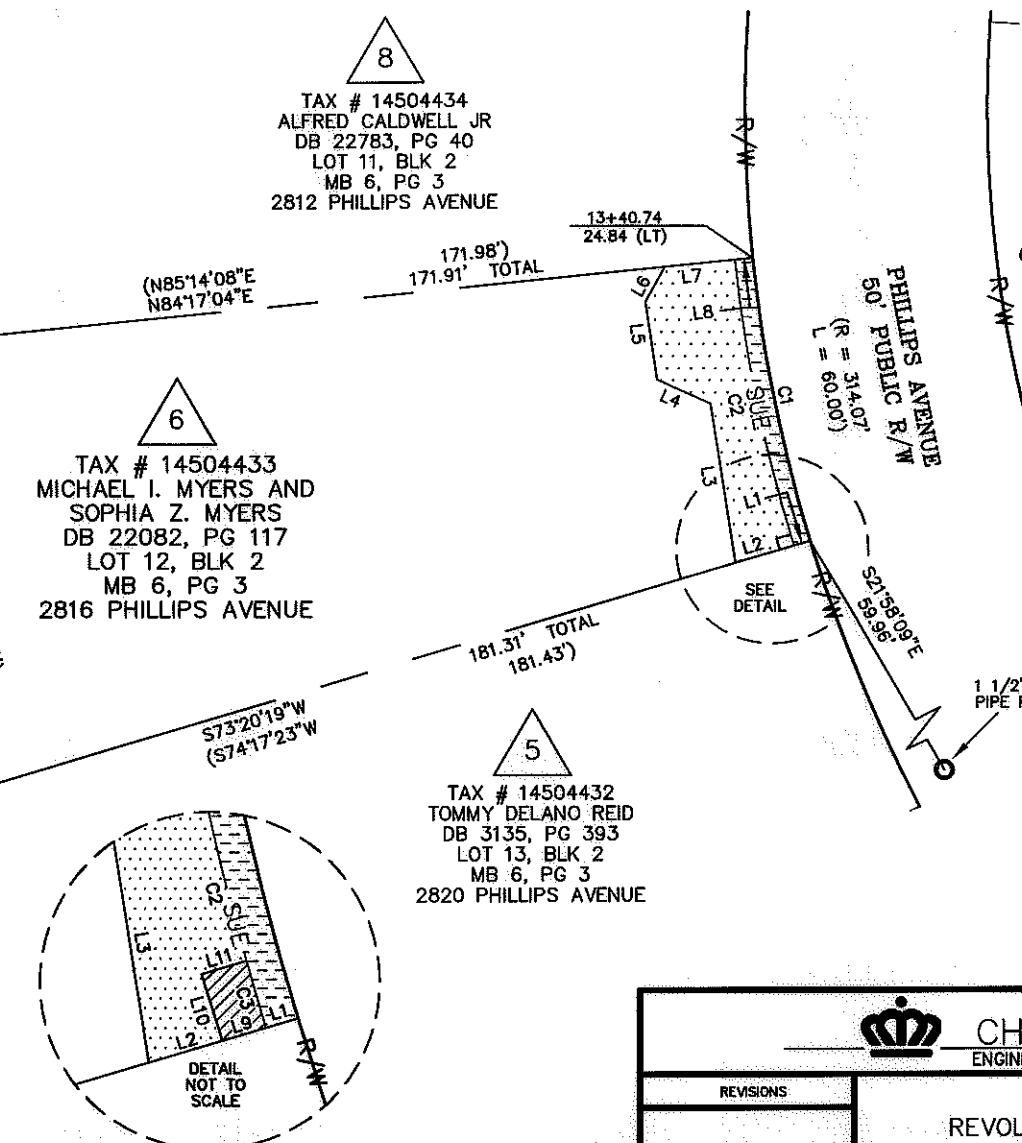
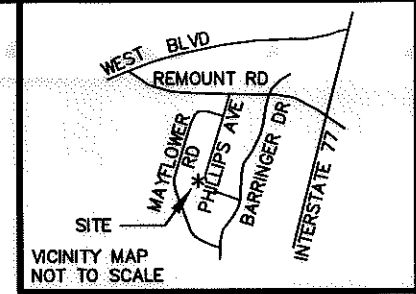

REVISIONS		CHARLOTTE ENGINEERING DEPARTMENT	JOB NO. 512-07-035
			FILE NO. PARCEL 6
0' SCALE 1" = 40'		PROPERTY ACQUISITION OWNER: MICHAEL I. MYERS AND SOPHIA Z. MYERS CHARLOTTE, MECKLENBURG CO., NC	SHEET 1
DRAWN BY: TTB	DATE: 03-29-2010		OF 1
		CHECKED BY: CJD	SURVEY SUPVR.: CJD