

PROJECT

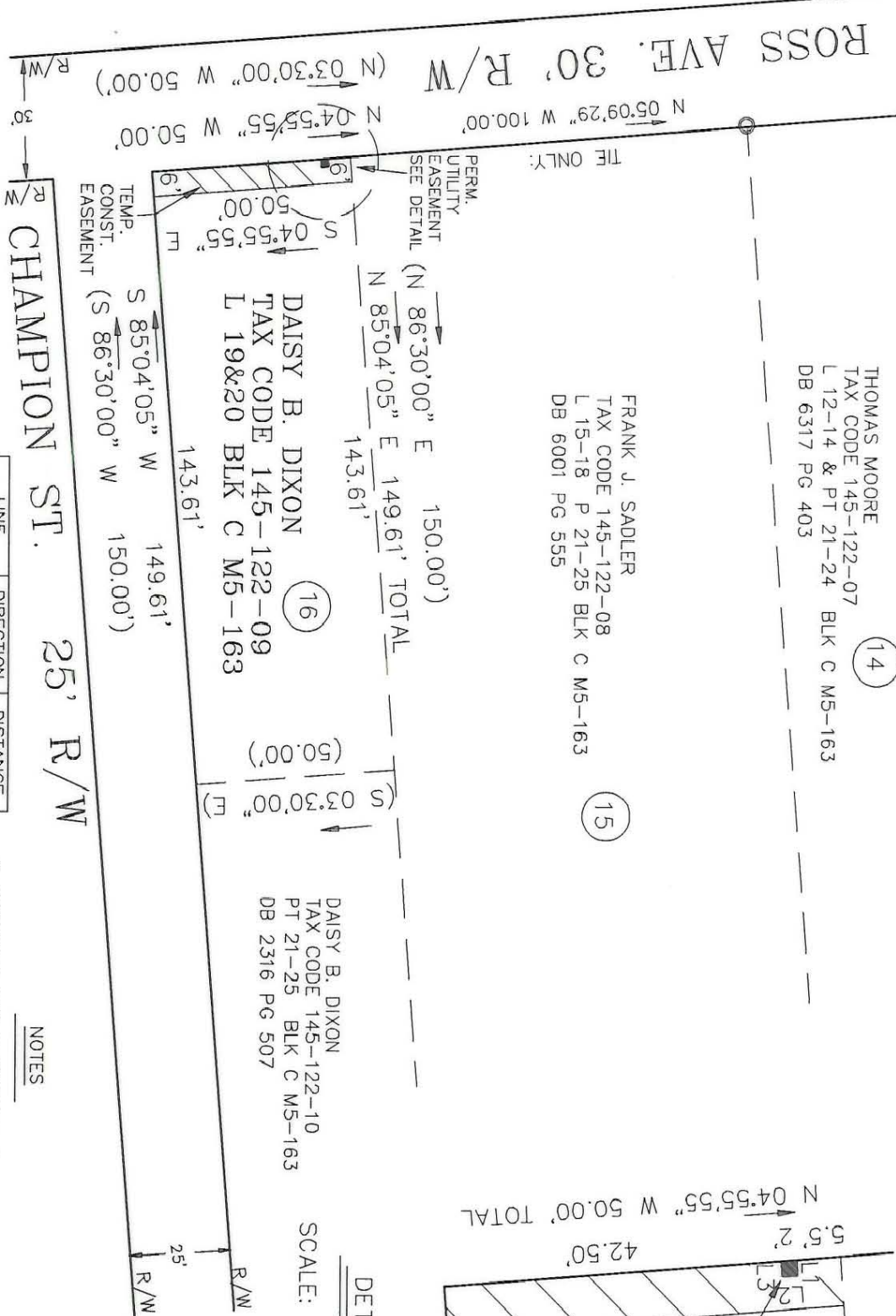
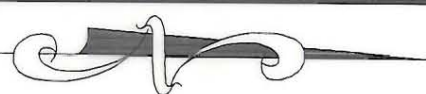

THOMAS MOORE
TAX CODE 145-122-07
L 12-14 & PT 21-24 BLK C M5-163
DB 6317 PG 403

FRANK J. SADLER
TAX CODE 145-122-08
L 15-18 P 21-25 BLK C M5-163
DB 6001 PG 555

DAISY B. DIXON
TAX CODE 145-122-09
L 19&20 BLK C M5-163

DAISY B. DIXON
TAX CODE 145-122-10
PT 21-25 BLK C M5-163
DB 2316 PG 507

LEGEND
IRON PIN FOUND

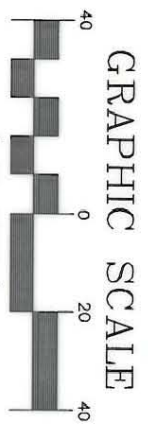

LINE	DIRECTION	DISTANCE
L1	N 85°04'05" E	2.00'
L2	S 04°55'55" E	2.00'
L3	S 85°04'05" W	2.00'

GRAPHIC SCALE

(IN FEET)
1 inch = 40 ft.

NOTES

- 1) BEARINGS AND DISTANCES SHOWN IN PARENTHESES ARE BASED ON DEED INFORMATION.
- 2) BROKEN LINES INDICATE PROPERTY NOT SURVEYED.
- 3) TOTAL AREA BY DEED 7,500 SQ.FT.
- 4) AREA OF PERMANENT UTILITY EASEMENT 4 SQ.FT.
- 5) AREA REMAINING 7,496 SQ.FT.
- 6) AREA OF TEMPORARY CONSTRUCTION EASEMENT 296 SQ.FT.

SCALE: 1"=20'

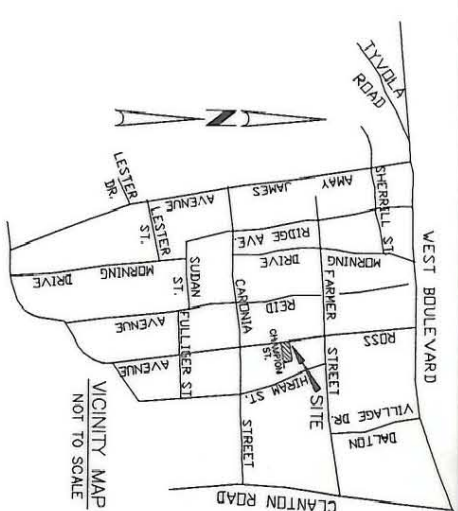
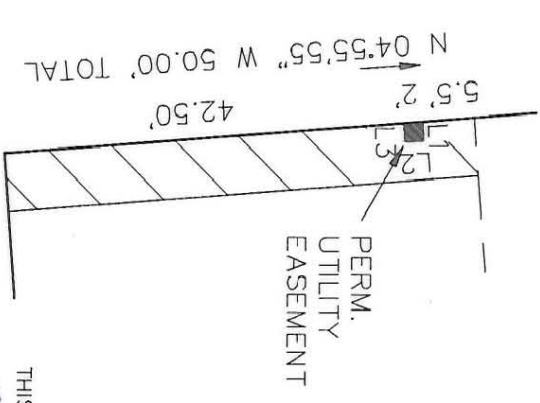

THIS PLAT WAS PREPARED UNDER MY SUPERVISION
N.C. REG. LAND SURVEYOR NO. L-1482
R. Dennis Smith 6-17-93

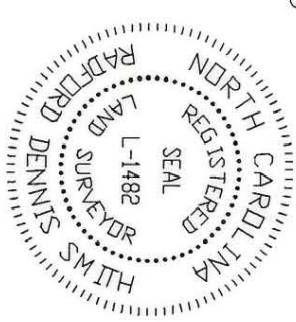

THIS PLAT WAS PREPARED FOR THE PURPOSE OF ACQUISITION ONLY, AND IS NOT INTENDED TO BE A BOUNDARY SURVEY OF PROPERTY SHOWN.

		CHARLOTTE ENGINEERING DEPARTMENT	
REVISIONS	JOB NO.	92076	FILE NO.
DRAWN BY CED CHECKED BY <i>RDS</i> SURVEY SVR.	PROPERTY OF DAISY B. DIXON CHARLOTTE, MECKLENBURG CO., NC	PARTS 1 SHEET 1 OF 1	DATE 05-07-93 SCALE 1"=40'

PREPARED BY:
CITY OF CHARLOTTE
ENGINEERING DEPARTMENT
600 EAST FOURTH STREET
CHARLOTTE, NC 28202
704-336-2291

DB 7445 PG 63, 67 145-122-09