

I, DAVID H. SNIDER, CERTIFY THAT THIS PLAT WAS PREPARED UNDER MY SUPERVISION AND THAT THE PLAT WAS PREPARED FOR THE PURPOSE OF ACQUISITION AND EASEMENTS ONLY, AND IS NOT INTENDED TO BE A BOUNDARY SURVEY OF PROPERTY SHOWN.

DAVID H. SNIDER, NC P.L.S. L-2942 DATE 01/28/03

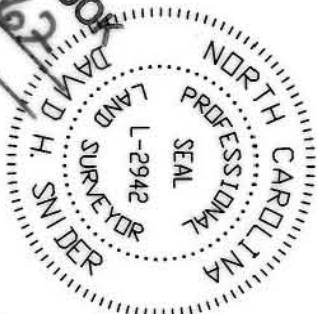

ACQUISITION BY CITY
RECORDED IN DEED BOOK
DATE 03-28-03

149-203-54
GREENAPPLE
INVESTMENT, LLC
DB 11138 PG 874
4300 PARK ROAD

LINE	BEARING	LENGTH
L1	S84°38'38"E	12.00
L2	S84°38'38"E	0.66
L3	N84°38'38"W	12.55
L4	N05°22'19"E	7.67
L5	S85°01'07"E	9.85
L6	N27°10'11"E	5.61
L7	N05°47'19"E	29.55
L8	S83°22'07"E	6.63
L9	N04°02'56"E	21.64

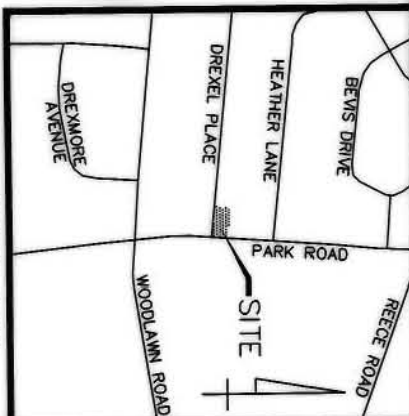
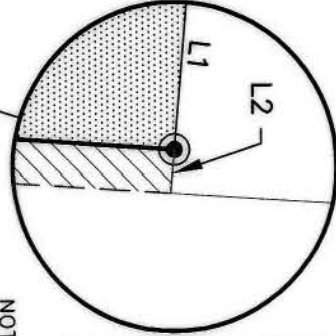

149-203-52
FAY H. & WINIFRED W.
CULBRETH
DB 5940 PG 201
1433 DREXEL PLACE

S84°38'38"E 137.33'
(S83°37'00"E 150.00' TOTAL)

N03°55'52"E 64.00'
(N04°57'30"E)

- LEGEND
- IRON PIN FOUND
 - #6 REBAR SET
 - ▨ AREA ACQUIRED
 - ▤ TEMP. CONSTRUCTION EASEMENT

149-203-53
FAY H. CULBRETH &
ROBERT H. POOLE, JR.
DB 5940 PG 201
4304 PARK ROAD

TEMP. CONSTRUCTION
EASEMENT

TEMP. CONSTRUCTION
EASEMENT LINE

NEW PROPERTY
LINE

PARK ROAD
(R/W VARIES)

- NOTE:
- 1) BEARINGS AND DISTANCES SHOWN IN PARENTHESES ARE BASED ON RECORDED MAP INFORMATION.
 - 2) TOTAL AREA 9,506 SQ.FT.
 - 3) TEMP. CONSTR. EASEMENT 1,067 SQ.FT.
 - 4) AREA ACQUIRED 62 SQ.FT.
 - 5) AREA REMAINING 9,444 SQ.FT.



NC GRID NAD83

N84°38'38"W
74.00'
(THE LINE)

(N83°37'00"W)
N84°38'38"W 117.45'

DREXEL PLACE
(50' R/W)

CURVE	RADIUS	LENGTH	CHORD	BEARING
C1	20.00	20.08	19.25	N34°07'00"E
C2	20.00	10.84	10.71	N78°24'15"E
C3	34.50	25.41	24.84	N24°50'28"E

State of North Carolina
County of Mecklenburg

Review Officer of Mecklenburg County,
certify that the map or plot to which this certification is
affixed meets all statutory requirements for recording.

Review Officer

Date

REVISIONS
1/03 - P.S.E. REMOVED

RADIUS IMPROVEMENT.
PARK ROAD & DREXEL PLACE

PROPERTY ACQUISITION
OWNERS: F.H. CULBRETH &
R.H. POOLE, JR.
CHARLOTTE, MECKLENBURG CO., NC

SCALE
1"=20'

DRAWN BY DLB

CHECKED BY

JOB NO. 03003
FILE NO.
DREXEL-PLAT2
SHEET 1 OF 1

PREPARED BY:
CITY OF CHARLOTTE
ENGINEERING DEPARTMENT
600 EAST FOURTH STREET
CHARLOTTE, NC 28202
704-336-2291

149-203-53