

I, R. DENNIS SMITH, CERTIFY THAT THIS PLAT WAS PREPARED UNDER MY SUPERVISION AND THAT THE PLAT WAS PREPARED FOR THE PURPOSE OF ACQUISITION AND EASEMENTS ONLY, AND IS NOT INTENDED TO BE A BOUNDARY SURVEY OF PROPERTY SHOWN.

R. Dennis Smith 2-11-97
 R. DENNIS SMITH, NC R.L.S. L-1482 DATE

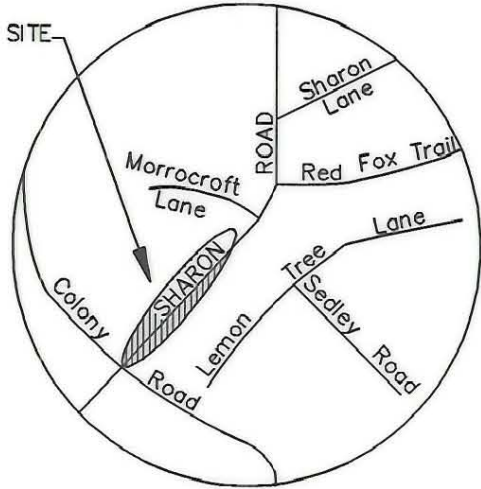

VICINITY MAP
N.T.S.

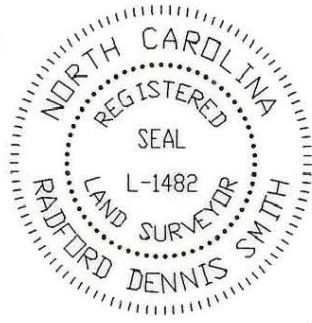
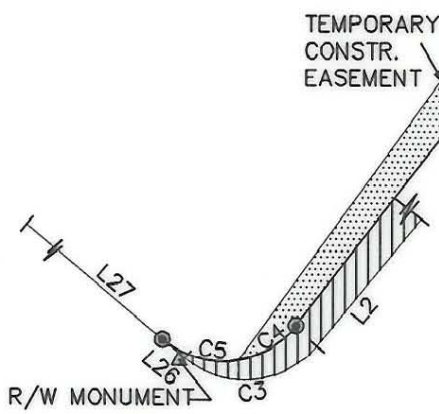

DETAIL "C"
SCALE: 1"=40'

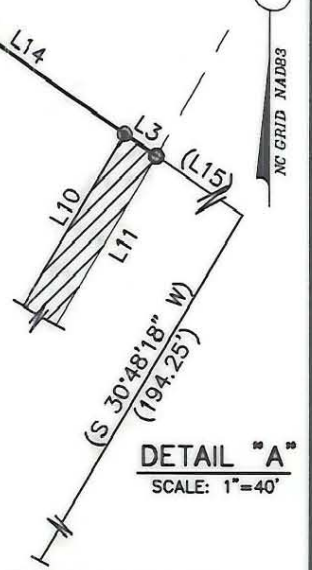

DETAIL "A"
SCALE: 1"=40'

LINE	DIRECTION	DISTANCE
L1	N 44°31'32" E	66.30'
L2	N 39°49'15" E	114.00'
L3	(S 56°03'20" E)	8.07'
(L4)	(S 26°46'50" E)	(57.97')
(L5)	(N 12°00'10" W)	(103.78')
(L6)	(N 42°36'27" E)	(83.30')
(L7)	(N 42°36'27" E)	(30.00')
L8	N 39°49'15" E	203.02'
*		
L10	N 30°53'53" E	128.86'
L11	S 30°47'27" W	198.74'
*		
*		
L14	(S 56°03'20" E)	122.29'
(L15)	(S 56°03'20" E)	(50.07')
L16	N 40°33'12" E	242.17'
*		
*		
*		
*		
L22	S 36°14'51" W	187.53'
L23	N 44°34'47" E	141.45'
L24	S 38°07'27" W	202.93'
L25	N 40°33'12" E	111.90'
L26	S 50°10'45" E	6.18'
L27	S 50°10'45" E	110.64'

NOTE:
 * DELETED AFTER REVISION
 C11=C4+C5

LEGEND

- IRON PIN FOUND ○
- IRON PIN SET ●
- RIGHT-OF-WAY MONUMENT ▲
- AREA ACQUIRED
- TEMPORARY CONSTRUCTION EASEMENT
- LINES SURVEYED ———
- LINES NOT SURVEYED - - - - -

CURVE	RADIUS	LENGTH	CHORD	BEARING
C1	973.72'	79.95'	79.93'	N 42°10'24" E
C2	973.72'	79.95'	79.93'	S 42°07'23" W
C3	20.00'	31.42'	28.29'	N 84°48'54" E
C4	20.00'	14.48'	14.17'	N 58°52'15" E
C5	20.00'	17.52'	16.97'	S 75°16'51" E
C6	977.70'	70.69'	70.67'	S 48°47'23" E
C7	3840.50'	647.20'	646.43'	N 35°43'32" E
C8	3779.72'	593.72'	593.11'	S 35°19'15" W
(C9)	(3848.56')	(605.59')	604.97'	S 35°18'46" W
(C10)	(1483.28')	(72.14')	72.13'	N 48°47'09" W
C11	20.00'	32.01'	28.70'	S 83°58'21" W

PREPARED BY:
 CITY OF CHARLOTTE
 ENGINEERING DEPARTMENT
 600 EAST FOURTH STREET
 CHARLOTTE, NC 28208
 704-336-2291

CHARLOTTE ENGINEERING DEPARTMENT		
REVISIONS	SHARON ROAD WIDENING PHASE II	JOB NO. 512-93-091
2- ADD C11 (DBS 7/03/97)	PROPERTY OF PAINE WEBBER QUALIFIED PLAN PROPERTY FUND CHARLOTTE, MECKLENBURG CO., NC	FILE NO.
1- ELIMINATE PERM. UTILITY EASEMENT. (DBS 2/10/97)		PLAT#
DRAWN BY DBS		SHEET 2
CHECKED BY <u>[Signature]</u>		OF 2
SURVEY SUPVR. <u>[Signature]</u>	DATE 8/5/96	SCALE AS SHOWN

177-092-05