

GLENEAGLES ROAD

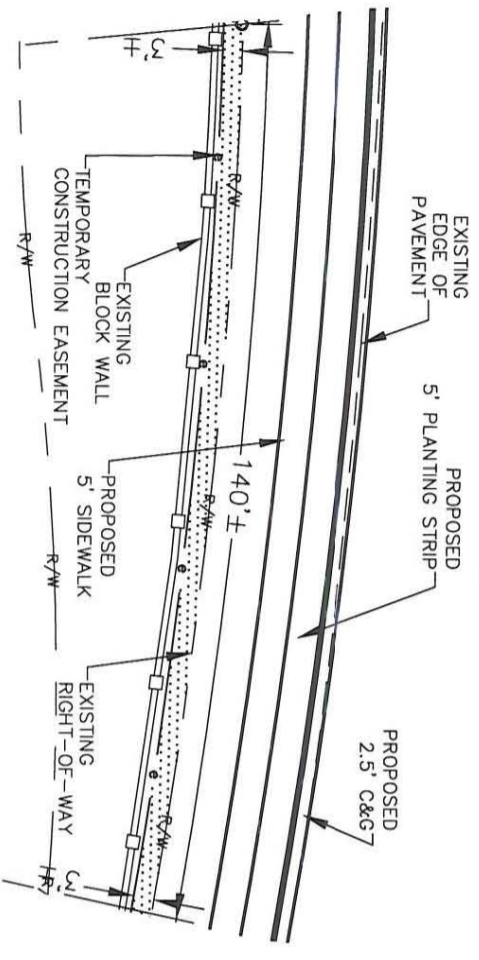

EAGLE GLEN ROAD

5

NOW OR FORMERLY
 GEORGE M. SCOTT, JR. AND SARA H. SCOTT
 MAP BOOK 31, PAGE 15
 D.B. 10562-899
 TAX PARCEL #209-382-31
 ZONED: R-15(CD)

GEORGE M. SCOTT, JR. AND SARA H. SCOTT 6734
 RED MAPLE DR.
 CHARLOTTE, N.C. 28277

- 1) TOTAL AREA = ±20,527 SQ. FT.
- 2) TEMPORARY CONSTRUCTION EASEMENT = ±439 SQ. FT.

ACQUISITION BY CITY
 RECORDED IN DEED BOOK
17013-292
 DATE **04-07-04**

LEGEND

- Temporary Construction Easement
- Existing Edge of Pavement
- Existing Property Line

GRAPHIC SCALE

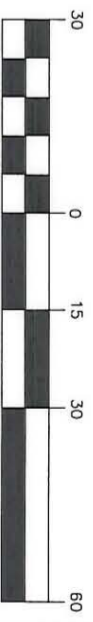

(IN FEET)
 1 inch = 30 ft.



**Kimley-Horn
 and Associates, Inc.**

4601 CHARLOTTE PARK DR, STE 350
 Charlotte, North Carolina 28217
 TEL: (704) 333-5131
 FAX: (704) 333-0945

Note:

This map is not a certified survey and has not been reviewed by a local government agency for compliance with any applicable land development regulations.

<p>CHARLOTTE ENGINEERING & PROPERTY MANAGEMENT DEPARTMENT</p>		<p>GEORGE & SARA SCOTT 6734 RED MAPLE DR. CHARLOTTE, N.C. 28277</p>	
		<p>TAX ID# 209-382-31 D.B. 10562 - PG. 899</p>	
<p>512-02-047 JOB NO. SS PREPARED BY</p>	<p>1" = 30' SCALE 11/04/03 DATE</p>	<p>015018\037\CADD\0150180228PLATS.DWG CAD FILE PATH</p>	

209-382-31