

LEGEND

- IRON PIN FOUND
- IRON PIN SET
- CALCULATED POINT
- LINE SURVEYED
- LINE NOT SURVEYED
- STORM DRAIN EASEMENT
- FEE SIMPLE OUTSIDE RIGHT-OF-WAY
- TEMP. CONST. EASEMENT
- SIDEWALK UTILITY EASEMENT

STORM DRAIN EASEMENT & SIDEWALK UTILITY EASEMENT OVERLAP

GALLOWAY RD. RIGHT-OF-WAY VARIES

029-012-24
INC ARBOR HILLS
HOMEOWNERS ASSOC AND
HAWTHORNE MANAGEMENT
DB 18208-441
OLDE IVY WY

N 583470.94
E 1477898.99

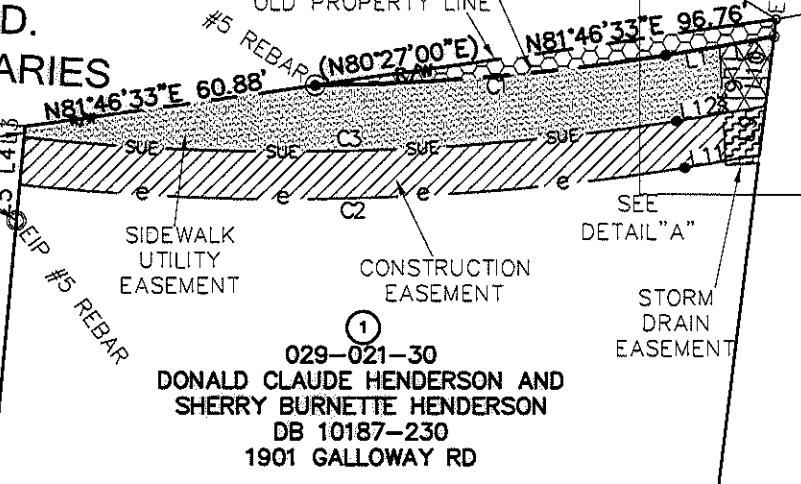
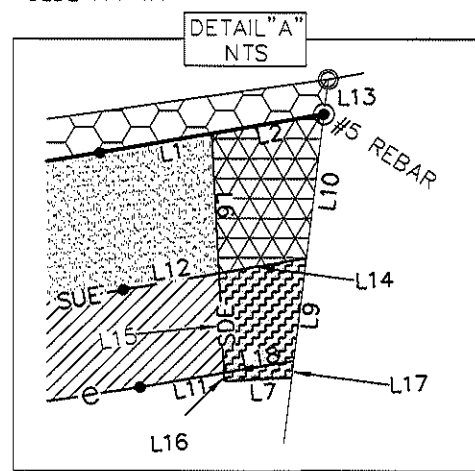

CURVE TABLE

CURVE	LENGTH	RADIUS	BEARING	CHORD
C1	73.20	488.14	N85°00'18"E	73.13
C2	138.71	512.14	N88°27'10"E	138.29
C3	136.12	502.14	N88°27'57"E	135.71

LINE	LENGTH	BEARING
L1	11.38	N80°04'18"E
L2	11.44	N80°04'18"E
L3	2.37	S05°12'54"W
L4	10.00	S05°12'54"W
L5	7.63	S05°12'54"W
L6	25.04	N02°57'10"W
L7	6.76	S86°36'24"W
L8	1.70	N06°55'57"E
L9	10.45	N06°55'57"E
L10	14.63	N06°55'57"E
L11	8.57	N80°04'18"E
L12	9.74	N80°04'18"E
L13	3.56	N06°55'57"E
L14	9.74	N80°04'18"E
L15	10.07	N02°57'10"W
L16	1.79	N02°57'10"W
L17	3.52	N06°55'57"E
L18	7.11	N80°04'18"E

- 1) BEARINGS AND DISTANCES SHOWN IN PARENTHESES ARE BASED ON RECORDED MAP INFORMATION.
- 2) TOTAL AREA 44,038 SQ. FT.
- 3) TEMP CONSTRUCTION EASEMENT 1,466 SQ. FT.
- 4) SIDEWALK UTILITY EASEMENT 1,719 SQ. FT.
- 5) STORM DRAIN EASEMENT 89 SQ. FT.
- 6) STORM DRAIN EASEMENT & SIDEWALK UTILITY EASEMENT OVERLAP 143 SQ. FT.
- 7) FEE SIMPLE R/W 305 SQ. FT.
- 8) AREA REMAINING 43.733 SQ. FT.

I, DAVID H. SNIDER, CERTIFY THAT THIS PLAT WAS PREPARED UNDER MY SUPERVISION AND THAT THE PLAT WAS PREPARED FOR THE PURPOSE OF ACQUISITION AND EASEMENTS ONLY, AND IS NOT INTENDED TO BE A BOUNDARY SURVEY OF PROPERTY SHOWN.

David H. Snider 5/14/09
DAVID H. SNIDER, NC P.L.S. L-2942 DATE

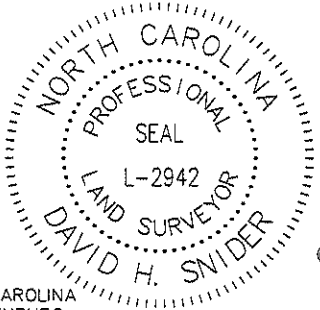

STATE OF NORTH CAROLINA
COUNTY OF MECKLENBURG

I, _____, REVIEW OFFICER OF MECKLENBURG COUNTY, CERTIFY THAT THE MAP OR PLAT TO WHICH THIS CERTIFICATION IS AFFIXED MEETS ALL STATUTORY REQUIREMENTS FOR RECORDING.

REVIEW OFFICER _____ DATE _____
PREPARED BY:
CITY OF CHARLOTTE
ENGINEERING DEPARTMENT
600 EAST FOURTH STREET
CHARLOTTE, NC 28202
704-336-2291

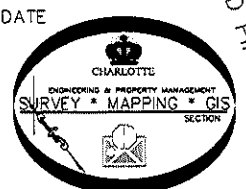

CHARLOTTE ENGINEERING DEPARTMENT

GALLOWAY RD. SIDEWALK

PROPERTY OF DONALD CLAUDE HENDERSON AND SHERRY BURNETTE HENDERSON, CHARLOTTE, MECKLENBURG CO., NC

REVISIONS	JOB NO. 512-08-077
REvised 5-14-09 REvised 3-17-09	SHEET 1
SCALE 1"=40'	OF 1
DRAWN BY P.S.	CHECKED BY DS SURVEY SUPVR. <i>DS</i>

K:\AutoCad\En_su-LD4\208077 Galloway Rd\dwg\Galloway Plats 1901 GALLOWAY RD P#1

DB 24830 p 276