

**VICINITY**  
N.T.S.

122

**CURRIN-PATTERSON PROPERTIES**  
WWT HARRIS BLYD.  
DB 11142 PG 701  
TAX \*03725317

LINE	DIRECTION	DISTANCE
L1	N 10° 59' 52" E	7.74 FT.
L2	N 76° 33' 38" E	7.80 FT.
L3	N 12° 57' 30" E	141.27 FT.
L4	N 2° 52' 52" W	24.08 FT.
L5	S 83° 16' 51" E	17.90 FT.
L6	S 83° 16' 51" E	24.02 FT.
L7	S 13° 18' 08" W	180.47 FT.
L8	N 76° 39' 44" W	16.72 FT.
L9	N 76° 39' 44" W	24.02 FT.
L10	N 11° 00' 02" E	6.82 FT.
L11	N 11° 00' 02" E	20.93 FT.
L12	N 11° 00' 02" E	150.10 FT.
L13	N 63° 16' 25" W	11.58 FT.
L14	S 27° 53' 03" W	19.80 FT.
L15	S 62° 06' 58" E	17.66 FT.

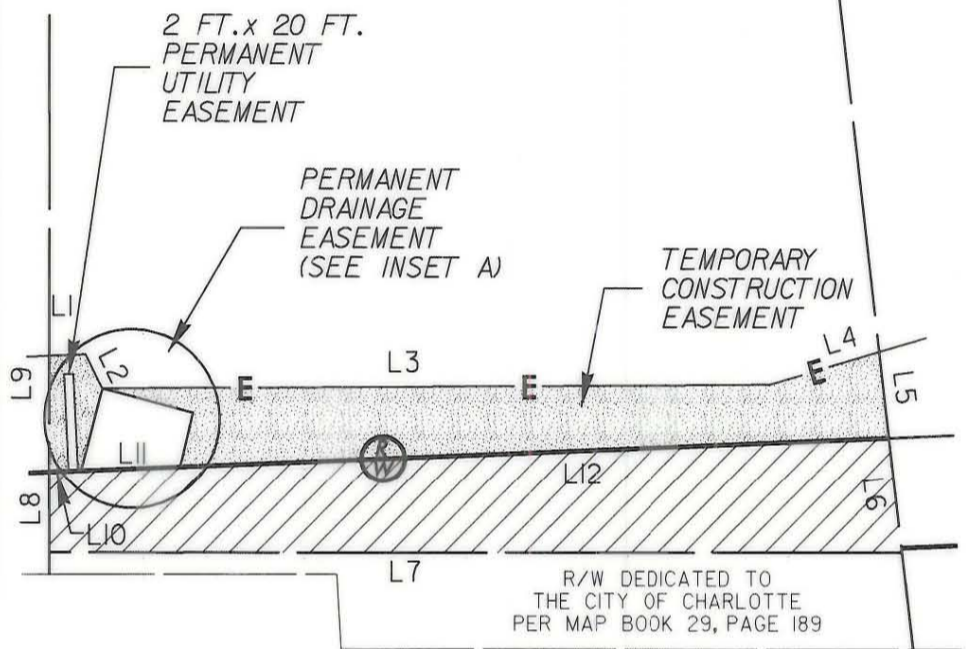

**OLD STATESVILLE ROAD**

I, MARK FUNKHOUSER, CERTIFY THAT THIS PLAT WAS PREPARED UNDER MY SUPERVISION AND THAT THE PLAT WAS PREPARED FOR THE PURPOSE OF ACQUISITION AND EASEMENTS ONLY, AND IS NOT INTENDED TO BE A BOUNDARY SURVEY OF PROPERTY SHOWN

*Mark Funkhouser* 8-27-01

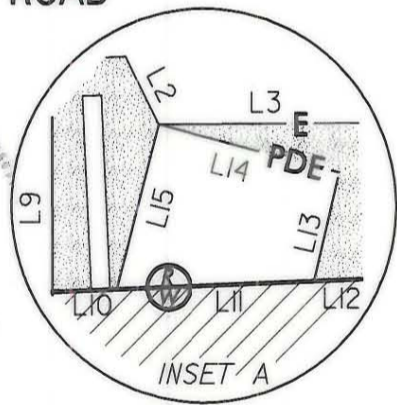

AREA FROM DEED OR TAX OFFICE	AREA ACQUIRED	RECORD AREA LESS AREA ACQUIRED	TEMPORARY CONSTRUCTION AREA	PERMANENT UTILITY EASEMENT	PERMANENT DRAINAGE EASEMENT
40,206 SQ. FT. 0.923 ACRES	3,638 SQ. FT. 0.084 ACRES	36,568 SQ. FT. 0.839 ACRES	2,339 SQ. FT. 0.054 ACRES	40 SQ. FT.	292 SQ. FT. 0.007 ACRES



**LEGEND**

- EXISTING IRON PIN
- SET IRON PIN
- NEW PROPERTY LINE
- AREA ACQUIRED
- TEMPORARY CONSTRUCTION EASEMENT

**PBSJ** Plans Prepared By  
200 EAST WOODLAWN ROAD, SUITE 310  
CHARLOTTE, NORTH CAROLINA 28217

ACQUIRED IN  
13571-374  
05-08-2002

REVISIONS	<b>OLD STATESVILLE ROAD WIDENING PROJECT</b>	JOB NO. 512-99-015
8/27/01		FILE NO. PLAT 122
DRAWN BY: CTC/CRT	<b>PROPERTY ACQUISITION CURRIN-PATTERSON PROPERTIES</b> CHARLOTTE, MECKLENBURG CO., NC	SHEET 1
CHECKED BY: MED		OF
SURVEY SUPVR.		1
DATE: 6/4/01		SCALE: 1"=40'