

I, DAVID H. SNIDER, CERTIFY THAT THIS PLAT WAS PREPARED UNDER MY SUPERVISION AND THAT THE PLAT WAS PREPARED FOR THE PURPOSE OF ACQUISITION AND EASEMENTS ONLY, AND IS NOT INTENDED TO BE A BOUNDARY SURVEY OF PROPERTY SHOWN.

David H. Snider 12/16/2010
 DAVID H. SNIDER, NC P.L.S. L-2942 DATE

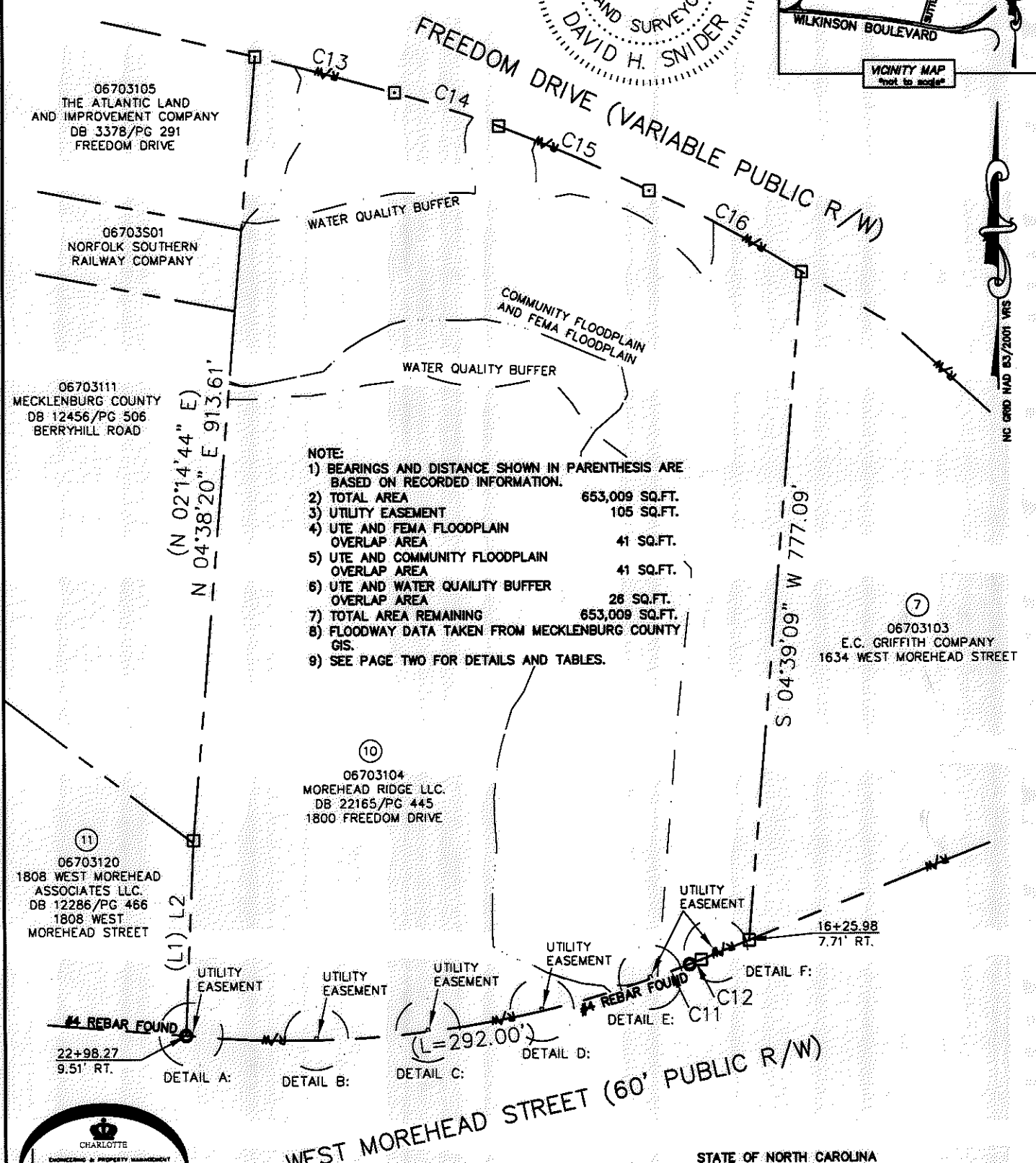

- NOTE:
- 1) BEARINGS AND DISTANCE SHOWN IN PARENTHESIS ARE BASED ON RECORDED INFORMATION.
 - 2) TOTAL AREA 653,009 SQ.FT.
 - 3) UTILITY EASEMENT 105 SQ.FT.
 - 4) UTE AND FEMA FLOODPLAIN OVERLAP AREA 41 SQ.FT.
 - 5) UTE AND COMMUNITY FLOODPLAIN OVERLAP AREA 41 SQ.FT.
 - 6) UTE AND WATER QUALITY BUFFER OVERLAP AREA 28 SQ.FT.
 - 7) TOTAL AREA REMAINING 653,009 SQ.FT.
 - 8) FLOODWAY DATA TAKEN FROM MECKLENBURG COUNTY GIS.
 - 9) SEE PAGE TWO FOR DETAILS AND TABLES.

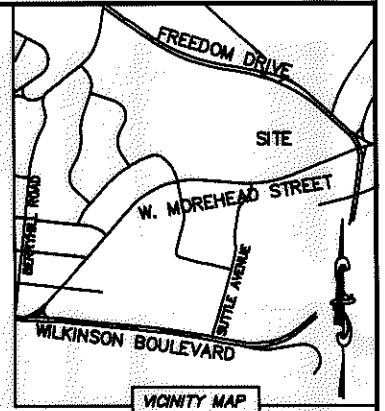
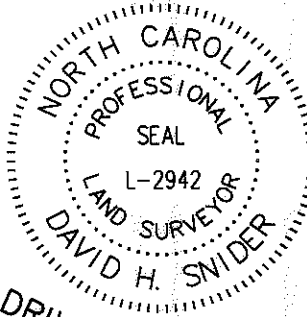
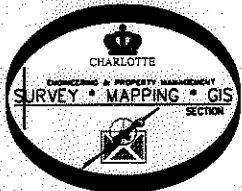

LEGEND

- REBAR OR IRON PIN FOUND
- COMPUTED POINT
- PROPERTY LINES
- EXISTING RIGHT-OF-WAY
- UTILITY EASEMENT
- WATER QUALITY BUFFER
- COMMUNITY FLOODPLAIN
- FEMA FLOODPLAIN
- UTILITY EASEMENT

PREPARED BY:
 CITY OF CHARLOTTE
 ENGINEERING & PROPERTY MANAGEMENT
 600 EAST FOURTH STREET
 CHARLOTTE, NC 28202
 704-336-2291

STATE OF NORTH CAROLINA
 COUNTY OF MECKLENBURG

I, _____ REVIEW OFFICER OF MECKLENBURG COUNTY, CERTIFY THAT THE MAP OR PLAT TO WHICH THIS CERTIFICATION IS AFFIXED MEETS ALL STATUTORY REQUIREMENTS FOR RECORDING.

REVIEW OFFICER _____ DATE _____

		CHARLOTTE ENGINEERING & PROPERTY MANAGEMENT	
REVISIONS		JOB NO. 512-09-038	
12/16/2010 - CHANGE OWNERS NAME TO MATCH DEED.		FILE NO. 067-031-04	
PROPERTY ACQUISITION		OWNER: MOREHEAD RIDGE LLC.	
DRAWN BY LG		CHARLOTTE, MECKLENBURG CO., NC	
DATE		CHECKED BY DHS SURVEY SUPVR. <i>DHS</i>	
K:\AUTOCAD\EN_SU-LD4\209038\PLATS\PARCEL 10.DWG		SHEET 1 OF 2	

I, DAVID H. SNIDER, CERTIFY THAT THIS PLAT WAS PREPARED UNDER MY SUPERVISION AND THAT THE PLAT WAS PREPARED FOR THE PURPOSE OF ACQUISITION AND EASEMENTS ONLY, AND IS NOT INTENDED TO BE A BOUNDARY SURVEY OF PROPERTY SHOWN.

David H. Snider 12/16/2010
 DAVID H. SNIDER, NC P.L.S. L-2942 DATE

STATE OF NORTH CAROLINA
 COUNTY OF MECKLENBURG

REVIEW OFFICER OF MECKLENBURG COUNTY,
 CERTIFY THAT THE MAP OR PLAT TO WHICH THIS CERTIFICATION IS
 AFFIXED MEETS ALL STATUTORY REQUIREMENTS FOR RECORDING.

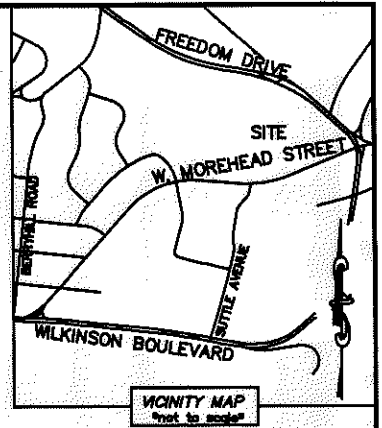
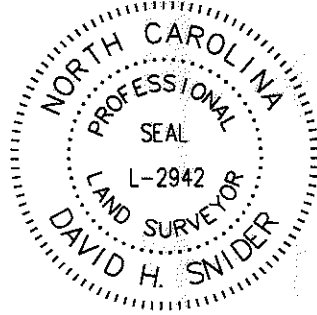

REVIEW OFFICER _____ DATE _____

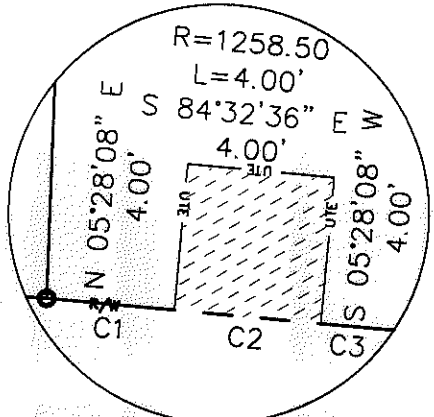

DETAIL A:
 (NOT TO SCALE)

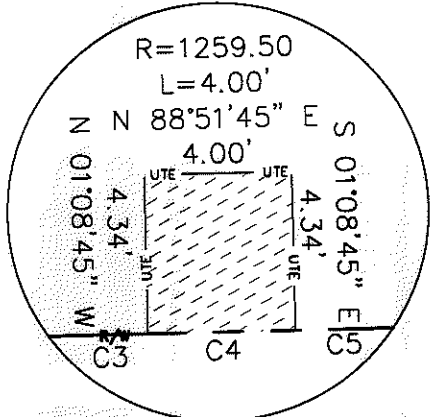

DETAIL B:
 (NOT TO SCALE)

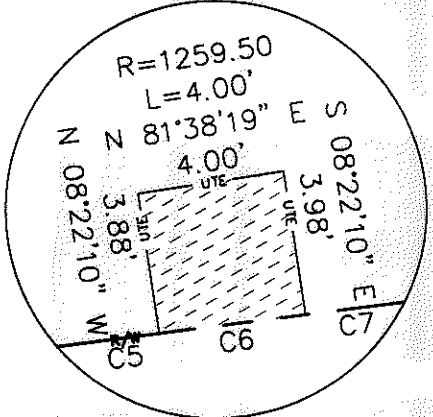

DETAIL C:
 (NOT TO SCALE)

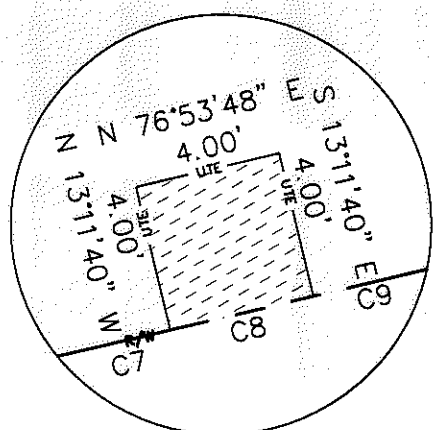

DETAIL D:
 (NOT TO SCALE)

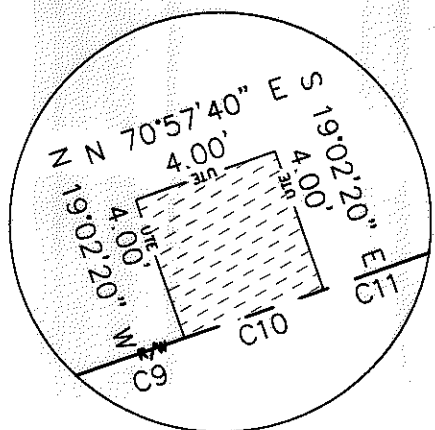

DETAIL E:
 (NOT TO SCALE)

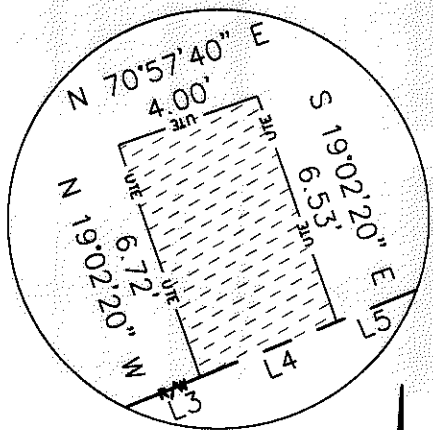

DETAIL F:
 (NOT TO SCALE)

CURVE TABLE		
CURVE	RADIUS & ARC	CHORD
C1	R=1262.50 L=3.47'	N 84°22'26" W 3.47'
C2	R=1262.50 L=4.00'	N 84°32'36" W 4.00'
C3	R=1262.50 L=141.52'	N 87°50'43" W 141.44'
C4	R=1262.50 L=4.00'	S 88°51'10" W 4.00'
C5	R=1262.50 L=125.74'	S 85°54'32" W 125.69'
C6	R=1262.50 L=4.00'	S 83°26'26" W 4.00'
C7	R=1262.50 L=129.71'	S 79°54'56" W 129.66'
C8	R=1262.50 L=4.00'	S 76°48'20" W 4.00'
C9	R=1262.50 L=126.78'	S 73°55'44" W 126.73'
C10	R=1262.50 L=4.00'	S 70°57'40" W 4.00'
C11	R=1262.50 L=45.89'	S 69°49'45" W 45.88'
C12	R=1262.50 L=14.50'	S 68°27'33" W 14.50'
C13	R=6224.20 L=166.85'	S 75°38'04" E 166.84'
C14	R=1582.03 L=126.14'	S 71°45'59" E 126.11'
C15	R=2015.87 L=189.30'	S 66°30'53" E 189.23'
C16	R=1344.70 L=200.53'	S 61°36'57" E 200.35'

LINE TABLE		
LINE	LENGTH	BEARING
L1	(225.59')	(N 00°02'05" E)
L2	222.59'	N 02°25'41" E
L3	17.31'	S 68°07'49" W
L4	4.00'	S 68°07'49" W
L5	38.73'	S 68°07'49" W

LEGEND

- REBAR OR IRON PIN FOUND
- COMPUTED POINT
- PROPERTY LINES
- EXISTING RIGHT-OF-WAY
- UTILITY EASEMENT
- WATER QUALITY BUFFER
- COMMUNITY FLOODPLAIN
- FEMA FLOODPLAIN
- UTILITY EASEMENT

PREPARED BY:
 CITY OF CHARLOTTE
 ENGINEERING & PROPERTY MANAGEMENT
 600 EAST FOURTH STREET
 CHARLOTTE, NC 28202
 704-336-2291

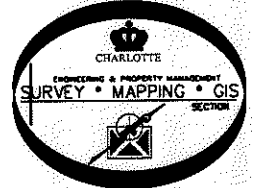

NC CDD 8/23/2001 WES

CHARLOTTE ENGINEERING & PROPERTY MANAGEMENT		
REVISIONS	BRYANT PARK PLAN	JOB NO. 512-09-038
12/16/2010 - CHANGE OWNERS NAME TO MATCH DEED.		FILE NO. 067-031-04
DRAWN BY LG	PROPERTY ACQUISITION	SHEET 2
DATE	OWNER: MOREHEAD RIDGE LLC.	OF 2
	CHARLOTTE, MECKLENBURG CO., NC	
	CHECKED BY DHS SURVEY SUPR. <i>DNA</i>	
K:\AUTOCAD\EN_SU-LD4\209038\PLATS\PARCEL 10.DWG		