

VICINITY
N.T.S.

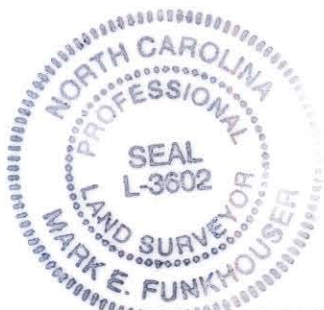

ACQUISITION BY DEED
RECORDED IN DEED BOOK
12809-768
DATE **10/29/2001**



MYRA D. PETTY
804 NORRIS AVE.
DB 6526 PG 161
TAX *08504207

(19)
RUBY MAE HARRELL
800 NORRIS AVE.
DB 2966 PG 587
TAX *08504208

I, MARK FUNKHOUSER, CERTIFY THAT THIS PLAT WAS PREPARED UNDER MY SUPERVISION AND THAT THE PLAT WAS PREPARED FOR THE PURPOSE OF ACQUISITION AND EASEMENTS ONLY, AND IS NOT INTENDED TO BE A BOUNDARY SURVEY OF PROPERTY SHOWN

Mark E. Funkhouser 7-16-01

LINE	DIRECTION	DISTANCE
L1	N 54° 53' 58" W	61.25 FT.
L2	N 32° 02' 07" E	3.63 FT.
L3	N 32° 02' 07" E	13.13 FT.
L4	S 57° 01' 08" E	52.39 FT.
L5	N 77° 44' 50" E	12.27 FT.
L6	S 32° 02' 08" W	16.70 FT.
L7	S 32° 02' 08" W	11.04 FT.
L8	S 55° 54' 11" E	53.87 FT.
L9	N 82° 25' 09" E	9.51 FT.

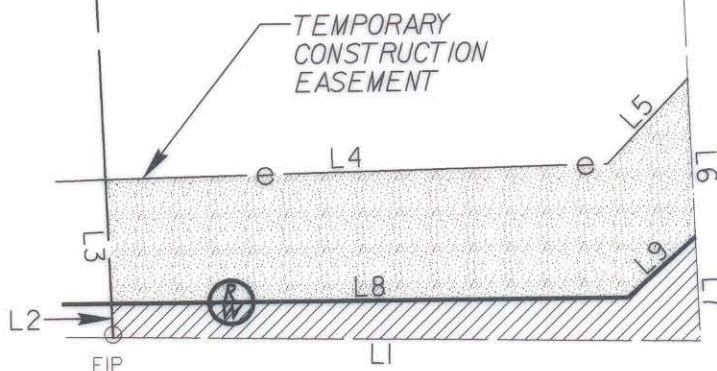

NORRIS AVENUE

AREA FROM DEED OR TAX OFFICE	AREA ACQUIRED	RECORD AREA LESS AREA ACQUIRED	TEMPORARY CONSTRUCTION AREA
8,581 SQ. FT. 0.197 ACRE	278 SQ. FT. 0.006 ACRE	8,303 SQ. FT. 0.191 ACRE	855 SQ. FT. 0.020 ACRE



LEGEND

- EXISTING IRON PIN
- SET IRON PIN
- NEW PROPERTY LINE
- AREA ACQUIRED
- TEMPORARY CONSTRUCTION EASEMENT

CHARLOTTE
ENGINEERING AND PROPERTY MANAGEMENT

REVISIONS DRAWN BY: VTS CHECKED BY: MED SURVEY SUPVR.	<p>GRAHAM STREET AT NORRIS AVENUE INTERSECTION IMPROVEMENT PROJECT</p> <p>PROPERTY ACQUISITION RUBY MAE HARRELL</p> <p>CHARLOTTE, MECKLENBURG CO., NC</p> <p>DATE: 7/16/01 SCALE: 1"=20'</p>	JOB NO. 512-00-072 FILE NO. PLAT 19 SHEET 1 OF 1
--	---	---