

I, _____, REVIEW OFFICER OF MECKLENBURG COUNTY, CERTIFY THAT THE MAP OR PLAT TO WHICH THIS CERTIFICATION IS AFFIXED MEETS ALL STATUTORY REQUIREMENTS OF NORTH CAROLINA GENERAL STATUTES FOR RECORDING.

REVIEW OFFICER _____ DATE _____

LEGEND

TCE = TEMPORARY CONSTRUCTION EASEMENT
 SUE = SIDEWALK & UTILITY EASEMENT
 SDE = STORM DRAINAGE EASEMENT

= TCE

= SDE

= FEE SIMPLE OUTSIDE EXISTING R/W

= SUE

= TCE

= EXISTING R/W

= SDE

= SUE

= IRON PIN FOUND

NOTE:

- 1) BEARINGS AND DISTANCES SHOWN IN PARENTHESES ARE BASED ON RECORDED MAP OR DEED INFORMATION.
- 2) TOTAL AREA: 206,477 SF; 4.740 AC
- 3) AREA IN TCE: 12,072 SF; 0.277 AC
- 4) AREA IN SUE: 12,511 SF; 0.287 AC
- 5) AREA IN SDE: 680 SF; 0.016 AC
- 6) FEE SIMPLE OUTSIDE EXISTING R/W: 4,576 SF; 0.105 AC
- 7) FEE AREA REMAINING: 201,901 SF; 4.635 AC

ACQUISITION BY DB 26681 PG 92



Plans Prepared By:
 5200 77 CENTER DRIVE, SUITE 500
 CHARLOTTE, NORTH CAROLINA 28217
 (704) 522-7275 NCCOA: F-0326

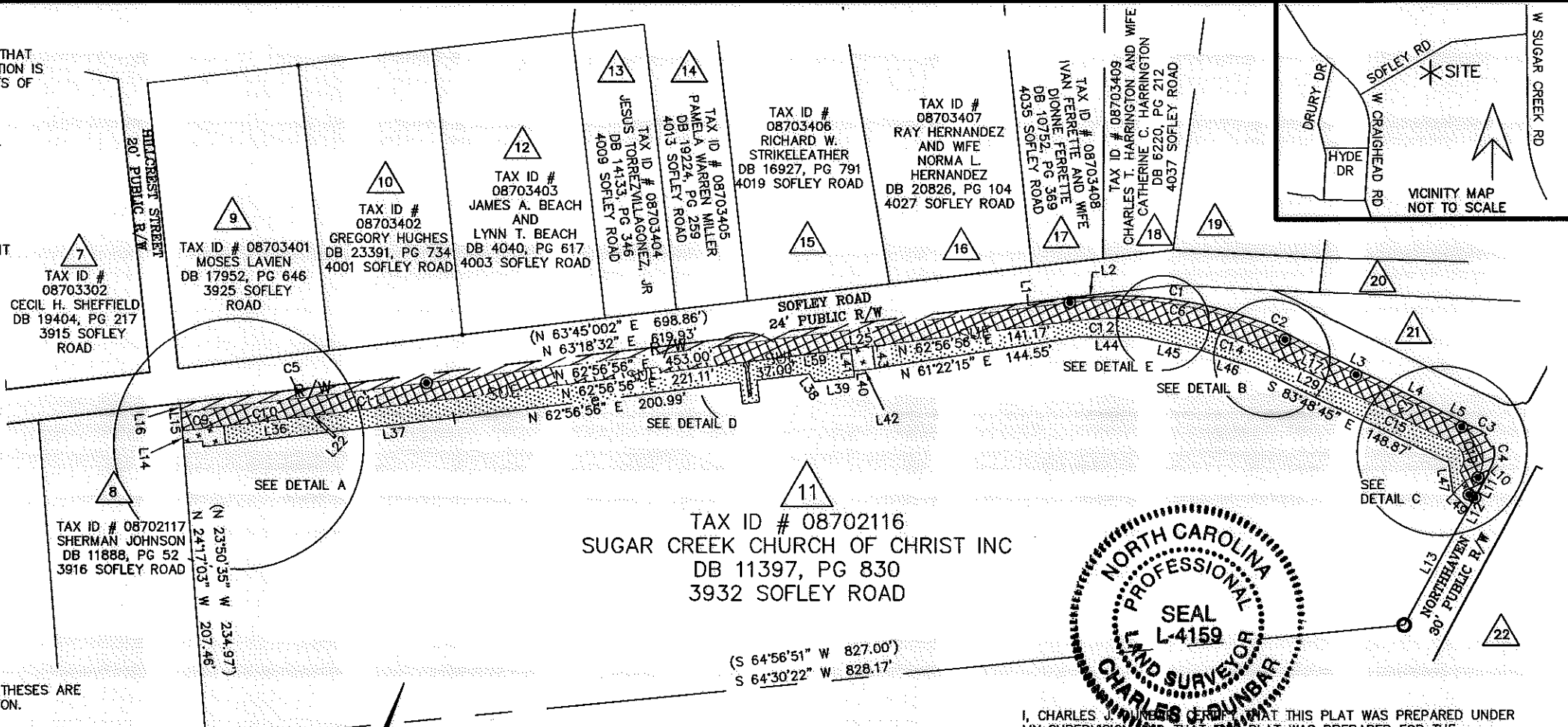

TAX ID # 08702116
 SUGAR CREEK CHURCH OF CHRIST INC
 DB 11397, PG 830
 3932 SOFLEY ROAD

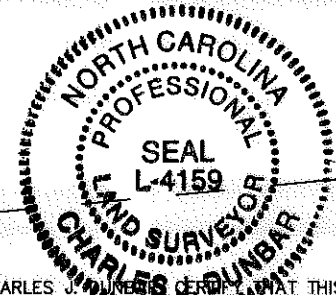

I, CHARLES J. DUNBAR, CERTIFY THAT THIS PLAT WAS PREPARED UNDER MY SUPERVISION AND THAT THIS PLAT WAS PREPARED FOR THE PURPOSE OF EASEMENTS ONLY, AND IS NOT INTENDED TO BE A BOUNDARY SURVEY OF PROPERTY SHOWN.

[Signature]
 CHARLES J. DUNBAR NC PLS L-4159
 DATE 01/19/10

CURVE TABLE				
CURVE	LENGTH	RADIUS	CHORD BRG	CHORD DIST
C1	89.54	292.22	S78°19'19"W	89.19
C2	55.77	218.35	N85°34'57"W	55.62
C3	5.11	16.66	N75°46'20"W	5.09
C4	11.95	19.56	N16°53'53"W	11.76
C5	172.84	13008.97	N63°19'43"E	172.84
C6	154.94	265.51	S79°37'45"W	152.75
C7	82.36	10017.79	S83°51'06"E	82.36
C8	40.52	25.50	N38°33'35"W	36.39
C9	29.16	13028.50	N63°38'50"E	29.16
C10	61.11	13028.50	N63°26'55"E	61.11
C11	80.49	13028.50	N63°07'33"E	80.49
C12	42.51	251.50	S67°43'21"W	42.46
C14	64.73	251.50	S89°26'51"W	64.55
C15	82.45	10028.50	S83°51'06"E	82.45
C16	11.04	43.00	S79°55'05"W	11.01
C17	19.80	57.00	N77°19'10"E	19.70
C18	11.04	43.00	S74°43'15"W	11.01
C19	22.32	12.50	N32°55'31"W	19.47

CHARLOTTE
ENGINEERING DEPARTMENT

REVISIONS	SUGAW CREEK / RITCH NIP	JOB NO.
1 - (08/04/2010) TCE REVISION		512-07-037
SCALE 1" = 100'	PROPERTY ACQUISITION OWNER: SUGAR CREEK CHURCH OF CHRIST, INC	FILE NO.
		PARCEL 11
DRAWN BY: EAV/TTB	CHARLOTTE, MECKLENBURG CO., NC	SHEET
DATE: 06-03-2010	CHECKED BY: CJD	1
	SURVEY SUPVR.: CJD	OF
		2

100004583v02_PARCEL11

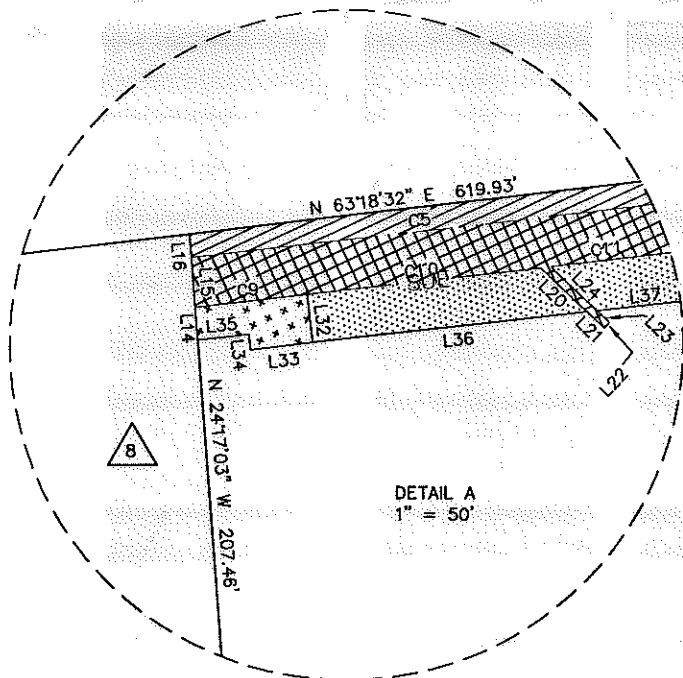

DETAIL A
1" = 50'

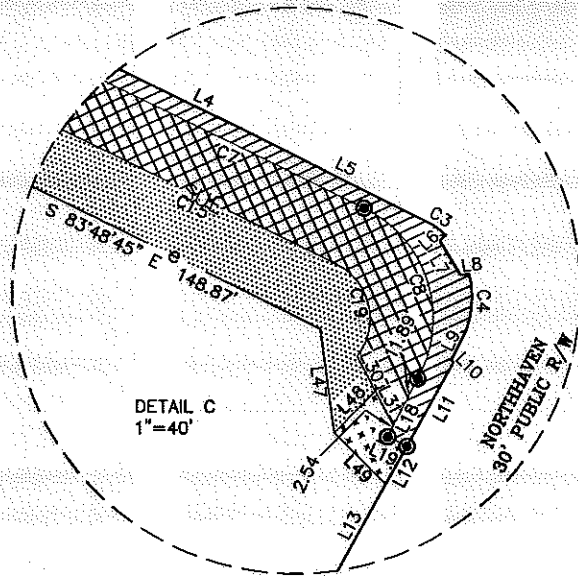

DETAIL C
1" = 40'

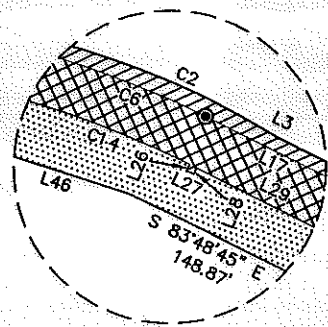

DETAIL B
1" = 50'

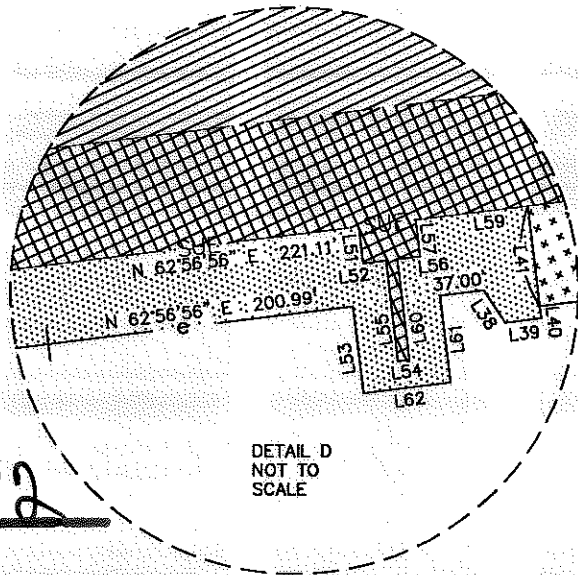

DETAIL D
NOT TO SCALE

LINE	LENGTH	BEARING
L1	0.48	N26°44'11"W
L2	36.83	S65°57'48"W
L3	64.76	S83°51'12"E
L4	25.70	S83°51'27"E
L5	39.96	S83°11'29"E
L6	1.74	S28°23'41"W
L7	8.30	S51°06'08"E
L8	1.80	N62°40'55"E
L9	6.86	S06°08'58"W
L10	0.67	S64°19'45"E
L11	19.80	S08°57'01"W
L12	8.99	S08°57'01"W
L13	92.79	S08°57'01"W
L14	8.48	N24°17'03"W
L15	13.01	N24°17'03"W
L16	6.10	N24°17'03"W
L17	55.00	S83°36'58"E
L18	14.43	S06°58'04"W
L19	4.41	N83°01'56"W
L20	16.53	S66°29'12"E
L21	6.11	S66°29'12"E
L22	2.00	N23°30'48"E
L23	4.42	S66°29'12"E
L24	16.55	S66°29'12"E
L25	14.62	N62°56'56"E
L26	1.77	S01°03'44"W
L27	2.01	S84°29'23"E
L28	1.74	N01°03'44"E
L29	51.22	S83°36'58"E
L30	8.19	S47°31'06"E
L31	8.08	S47°31'06"E
L32	12.50	N26°25'01"W
L33	16.05	N63°37'06"E
L34	4.00	N26°20'47"W
L35	13.43	N63°47'33"E
L36	71.75	N63°35'28"E
L37	86.10	N63°35'28"E
L38	6.71	S53°36'58"E
L39	28.00	N62°56'56"E
L40	4.00	S27°03'04"E
L41	15.50	N27°03'04"W
L42	15.00	N62°56'56"E
L43	15.50	N27°03'04"W
L44	42.72	N70°07'18"E
L45	42.49	N81°42'16"E
L46	42.37	N87°54'08"E
L47	21.67	S27°57'44"E
L48	12.10	S24°52'37"W
L49	15.14	S64°56'01"E
L50	13.27	N70°01'38"E
L51	3.05	S27°03'04"E
L52	1.00	N62°56'56"E
L53	15.00	S27°03'04"E
L54	2.00	N62°56'56"E
L55	20.76	S27°03'04"E
L56	1.00	N62°56'56"E
L57	3.05	N27°03'04"W
L58	16.27	S47°31'06"E
L59	72.00	N62°56'56"E
L60	20.76	S27°03'04"E
L61	15.00	N27°03'04"W
L62	12.00	N62°56'56"E

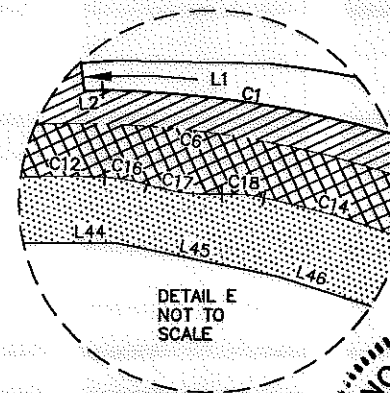
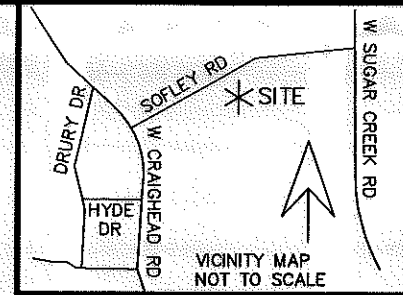

DETAIL E
NOT TO SCALE

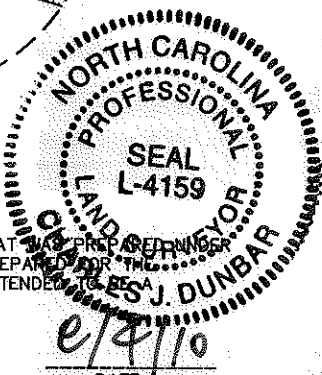

I, CHARLES J. DUNBAR, CERTIFY THAT THIS PLAT WAS PREPARED UNDER MY SUPERVISION AND THAT THIS PLAT WAS PREPARED FOR THE PURPOSE OF EASEMENTS ONLY, AND IS NOT INTENDED TO BE A BOUNDARY SURVEY OF PROPERTY SHOWN.

CHARLES J. DUNBAR NC PLS L-4159

DATE 100004583v02_PARCEL11

ACQUISITION BY DB 26681 PG 92

I, _____ REVIEW OFFICER OF MECKLENBURG COUNTY, CERTIFY THAT THE MAP OR PLAT TO WHICH THIS CERTIFICATION IS AFFIXED MEETS ALL STATUTORY REQUIREMENTS OF NORTH CAROLINA GENERAL STATUTES FOR RECORDING.

REVIEW OFFICER _____ DATE _____

PBSJ Plans Prepared By:
5200 77 CENTER DRIVE, SUITE 500
CHARLOTTE, NORTH CAROLINA 28217
(704) 522-7275 NCCOA: F-0326

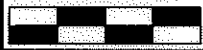
 CHARLOTTE ENGINEERING DEPARTMENT		JOB NO. 512-07-037
REVISIONS 1 - (08/04/2010) TCE REVISION	SUGAW CREEK / RITCH NIP	FILE NO. PARCEL 11
SCALE 1" = 100' 	PROPERTY ACQUISITION OWNER: SUGAR CREEK CHURCH OF CHRIST, INC	SHEET 2
DRAWN BY: EAV/TTB	CHARLOTTE, MECKLENBURG CO., NC	OF 2
DATE: 06-03-2010	CHECKED BY: CJD	SURVEY SUPVR.: CJD