

I R. DENNIS SMITH, CERTIFY THAT THIS PLAT WAS DRAWN UNDER MY SUPERVISION AND THAT THE PLAT WAS PREPARED FOR THE PURPOSE OF ACQUISITION FOR EASEMENTS ONLY, AND IS NOT INTENDED TO BE A BOUNDARY OF THE PROPERTY SHOWN.

R. Dennis Smith
 R. DENNIS SMITH 2-3-95
 N.C.R.L.S. L-1482

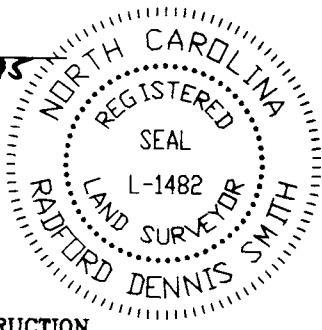

LEGEND:

- ⊙ IRON SET
- ⊙ IRON FOUND
- ⊗ AREA ACQUIRED
- ⊕ TEMPORARY CONSTRUCTION EASEMENT

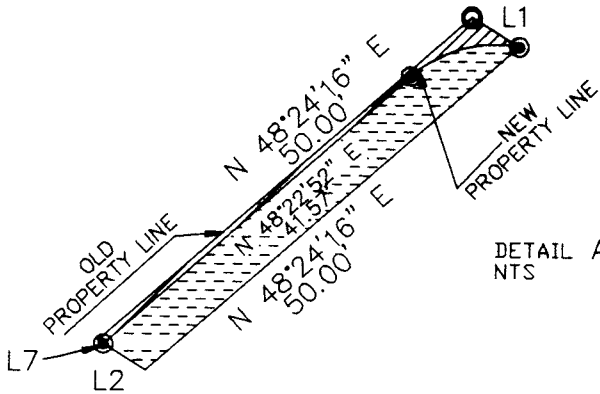
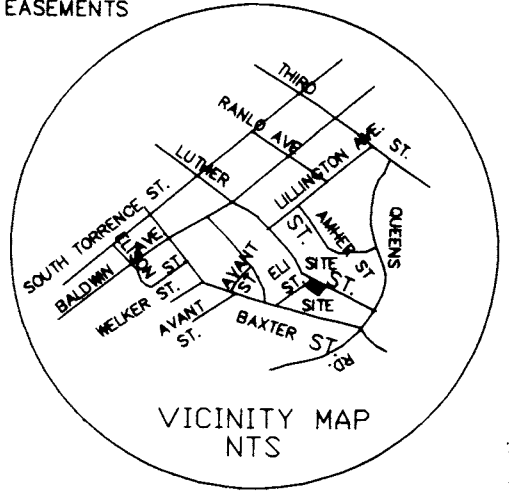

R = 12.50'
 L = 11.43'
 CHORD LENGTH = 11.03'
 CHORD BEARING = S74°20'01"W

DETAIL A
 NTS

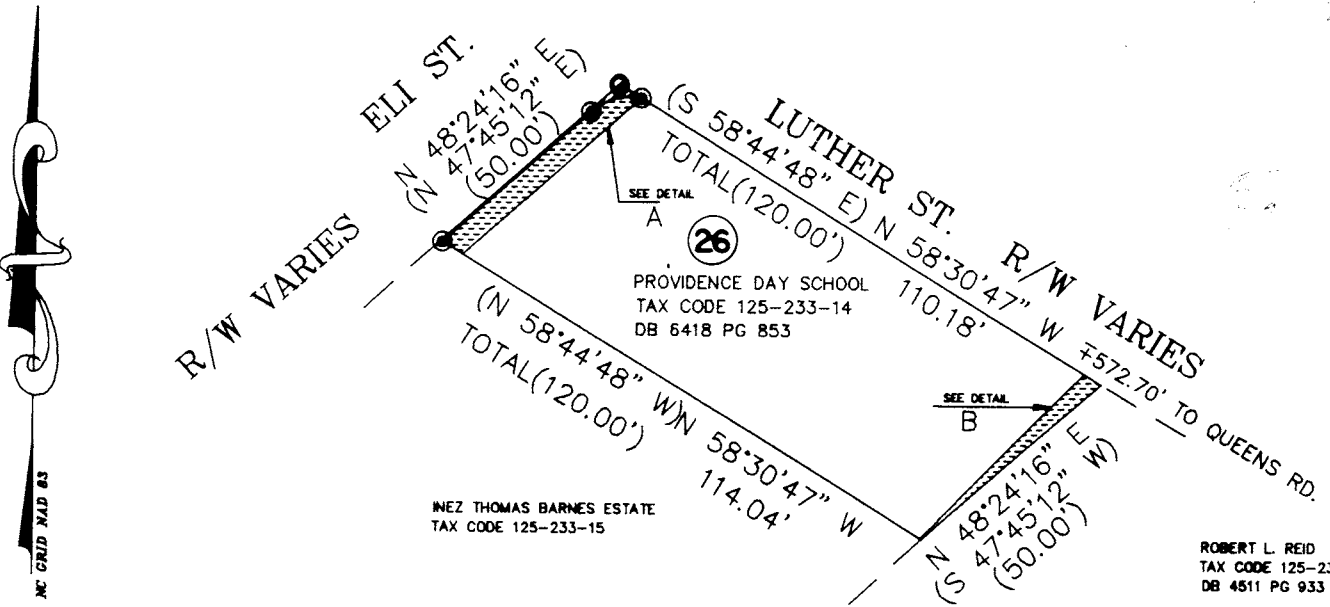

LINE	DIRECTION	DISTANCE
L1	S 58°30'47" E	5.50'
L2	N 58°30'47" W	5.07'
L3	S 58°30'47" E	4.22'
L4	S 48°24'16" W	50.00'
L5	N 44°04'25" E	49.01'
L6	N 58°30'47" W	.35'
L7	N 58°30'47" E	.43'

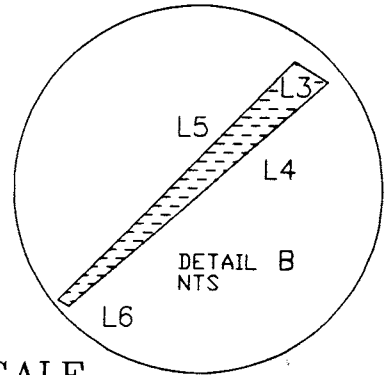

DETAIL B
 NTS

GRAPHIC SCALE



NOTES:

- TOTAL AREA BY DEED = 5,753 SQ. FT.
 AREA ACQUIRED = 31 SQ. FT.
 AREA REMAINING = 5,722 SQ. FT.
 TEMPORARY CONSTRUCTION EASEMENT = 341 SQ. FT.
- BEARINGS AND DISTANCES SHOWN IN PARENTHESES ARE BASED ON A RECORDED MAP IN THE MECKLENBURG COUNTY PUBLIC REGISTRY IN MB 332, PG 317.

(IN FEET)

1 inch = 40 ft.

PREPARED BY:
 CITY OF CHARLOTTE
 ENGINEERING DEPARTMENT
 600 EAST FOURTH STREET
 CHARLOTTE, NC 28202
 704-336-2291

CHARLOTTE ENGINEERING DEPARTMENT		
REVISIONS	IMPROVEMENTS TO CHERRY COMMUNITY PHASE II STORM DRAINAGE	JOB NO. (94706) 671-947-06
	PROPERTY OF PROVIDENCE DAY SCHOOL CHARLOTTE, MECK., CO., N.C.	FILE NO. PLAT-14
DRAWN BY N. COCKER		SHEET 1
CHECKED BY [Signature]		OF 1
SURVEY SVR.	DATE 1-95	SCALE 1"=40'

DB8148 PG320