

I, DAVID H. SNIDER, CERTIFY THAT THIS PLAT WAS PREPARED UNDER MY SUPERVISION AND THAT THE PLAT WAS PREPARED FOR THE PURPOSE OF ACQUISITION AND EASEMENTS ONLY, AND IS NOT INTENDED TO BE A BOUNDARY SURVEY OF PROPERTY SHOWN.

David H. Snider 10/13/11
 DAVID H. SNIDER, NC P.L.S. L-2942 DATE

STATE OF NORTH CAROLINA
 COUNTY OF MECKLENBURG

I, _____ REVIEW OFFICER OF MECKLENBURG COUNTY, CERTIFY THAT THE MAP OR PLAT TO WHICH THIS CERTIFICATION IS AFFIXED MEETS ALL STATUTORY REQUIREMENTS FOR RECORDING.

REVIEW OFFICER _____ DATE _____

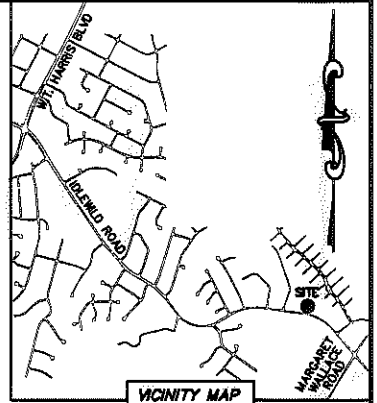

DETAIL A:
 (NOT TO SCALE)

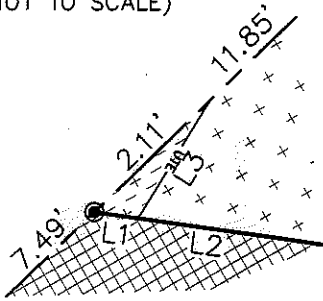

DETAIL B:
 (NOT TO SCALE)

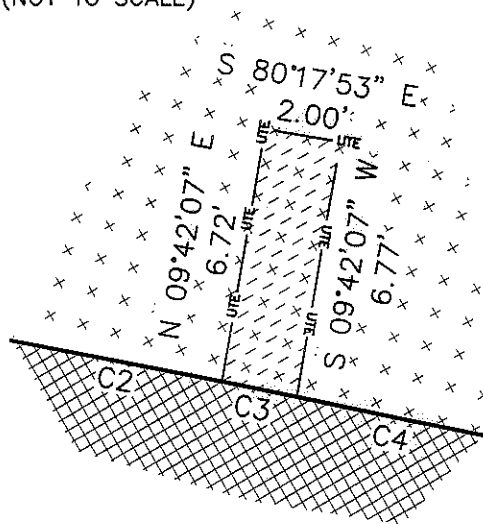

CURVE TABLE		
CURVE	RADIUS & ARC	CHORD
C1	R=1025.45 L=65.96'	N 80°02'48" W 65.95'
C2	R=1077.00 L=60.80'	S 80°20'16" E 60.79'
C3	R=1077.00 L=2.00'	S 78°40'02" E 2.00'
C4	R=1077.00 L=41.99'	S 77°29'50" E 41.98'
C5	R=1088.00 L=110.93'	S 79°02'02" E 110.88'

LINE TABLE		
LINE	LENGTH	BEARING
L1	0.58'	S 81°57'18" E
L2	85.10'	S 81°57'18" E
L3	1.81'	S 31°22'53" W
L4	77.09'	S 81°57'18" E
L5	115.89'	S 80°03'57" E
L6	76.46'	S 87°23'40" E

LEGEND

- REBAR OR IRON PIN FOUND
- #5 REBAR SET OR PK NAIL
- COMPUTED POINT
- R/W MONUMENT FOUND
- PROPERTY LINES
- EXISTING RIGHT-OF-WAY
- NEW RIGHT-OF-WAY
- STORM DRAINAGE EASEMENT
- UTILITY EASEMENT
- TEMP. CONSTRUCTION EASEMENT
- UTILITY EASEMENT
- FEE SIMPLE OUTSIDE EXIST R/W
- TEMP. CONSTRUCTION EASEMENT
- STORM DRAINAGE EASEMENT

PREPARED BY:
 CITY OF CHARLOTTE
 ENGINEERING & PROPERTY MANAGEMENT
 600 EAST FOURTH STREET
 CHARLOTTE, NC 28202
 704-336-2291

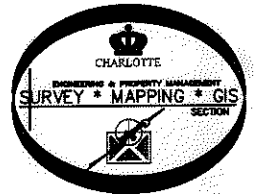

REVISIONS		JOB NO.	
IDLEWILD ROAD WIDENING		512-03-011	
		FILE NO. 135-163-08	
PROPERTY ACQUISITION OWNERS: DONALD LEM JOHNSON AND WIFE SHEILA P. JOHNSON CHARLOTTE, MECKLENBURG CO., NC		SHEET 2	
		OF 2	
DRAWN BY LG	CHECKED BY DHS	DATE	
K:\AUTOCAD\EN_SU-LD4\203011\dwg\IDLEWILD ROAD PLATS.DWG			

ACQUISITION BY DB 27284 PG 776-793