





LEGEND

TCE = TEMPORARY CONSTRUCTION EASEMENT
 SUE = PERMANENT SIDEWALK AND UTILITY EASEMENT

-  = TCE
-  = SUE
-  = TCE
-  = EXISTING R/W
-  = SUE
-  = IRON PIN FOUND

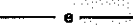
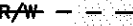
LINE TABLE		
LINE	LENGTH	BEARING
L1	6.77	N53°01'04"W
L2	11.13	N53°01'04"W
L3	119.81	N37°17'45"E
L4	114.07	N37°28'30"E

CURVE TABLE				
CURVE	LENGTH	RADIUS	CHORD BRG	CHORD DIST
C1	31.42	20.00	N08°01'04"W	28.28
C2	15.60	20.00	N14°37'57"E	15.21
C3	13.04	20.00	N26°23'38"W	12.81
C4	2.77	20.00	N49°02'39"W	2.77

I, CHARLES J. DUNBAR, CERTIFY THAT THIS PLAT WAS PREPARED UNDER MY SUPERVISION AND THAT THIS PLAT WAS PREPARED FOR THE PURPOSE OF EASEMENTS ONLY, AND IS NOT INTENDED TO BE A BOUNDARY SURVEY OF PROPERTY SHOWN.

CHARLES J. DUNBAR NC PLS L-4159

DATE 3/30/10



Plans Prepared By:
 5200 77 CENTER DRIVE, SUITE 500
 CHARLOTTE, NORTH CAROLINA 28217
 (704) 522-7275 NCCOA: F-0326

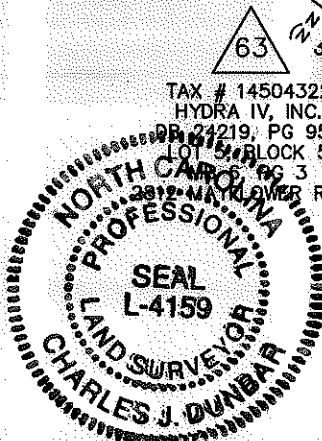

REVIEW OFFICER OF MECKLENBURG COUNTY, CERTIFY THAT THE MAP OR PLAT TO WHICH THIS CERTIFICATION IS AFFIXED MEETS ALL STATUTORY REQUIREMENTS OF NORTH CAROLINA GENERAL STATUTES FOR RECORDING.

REVIEW OFFICER _____ DATE _____

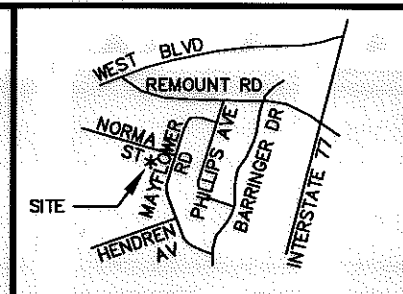

VICINITY MAP NOT TO SCALE

- NOTE:
- 1) BEARINGS AND DISTANCES SHOWN IN PARENTHESES ARE BASED ON RECORDED MAP OR DEED INFORMATION.
 - 2) TOTAL AREA: 11,314 SF, 0.260 AC
 - 3) AREA IN TCE: 1,332 SF, 0.031 AC
 - 4) AREA IN SUE: 691 SF, 0.016 AC
 - 5) FEE AREA REMAINING: 11,314 SF, 0.260 AC

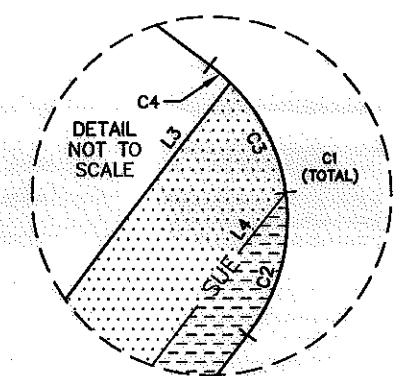

100004583v01_PARCEL 65

		JOB NO. 512-07-035
CHARLOTTE ENGINEERING DEPARTMENT		
REVOLUTION PARK NIP		FILE NO. PARCEL 65
PROPERTY ACQUISITION OWNER: LIBERTY CORNER PROPERTIES, LLC CHARLOTTE, MECKLENBURG CO., NC		SHEET 1 OF 1
REVISIONS	DATE: 03-30-2010	CHECKED BY: CJD SURVEY SUPVR.: CJD

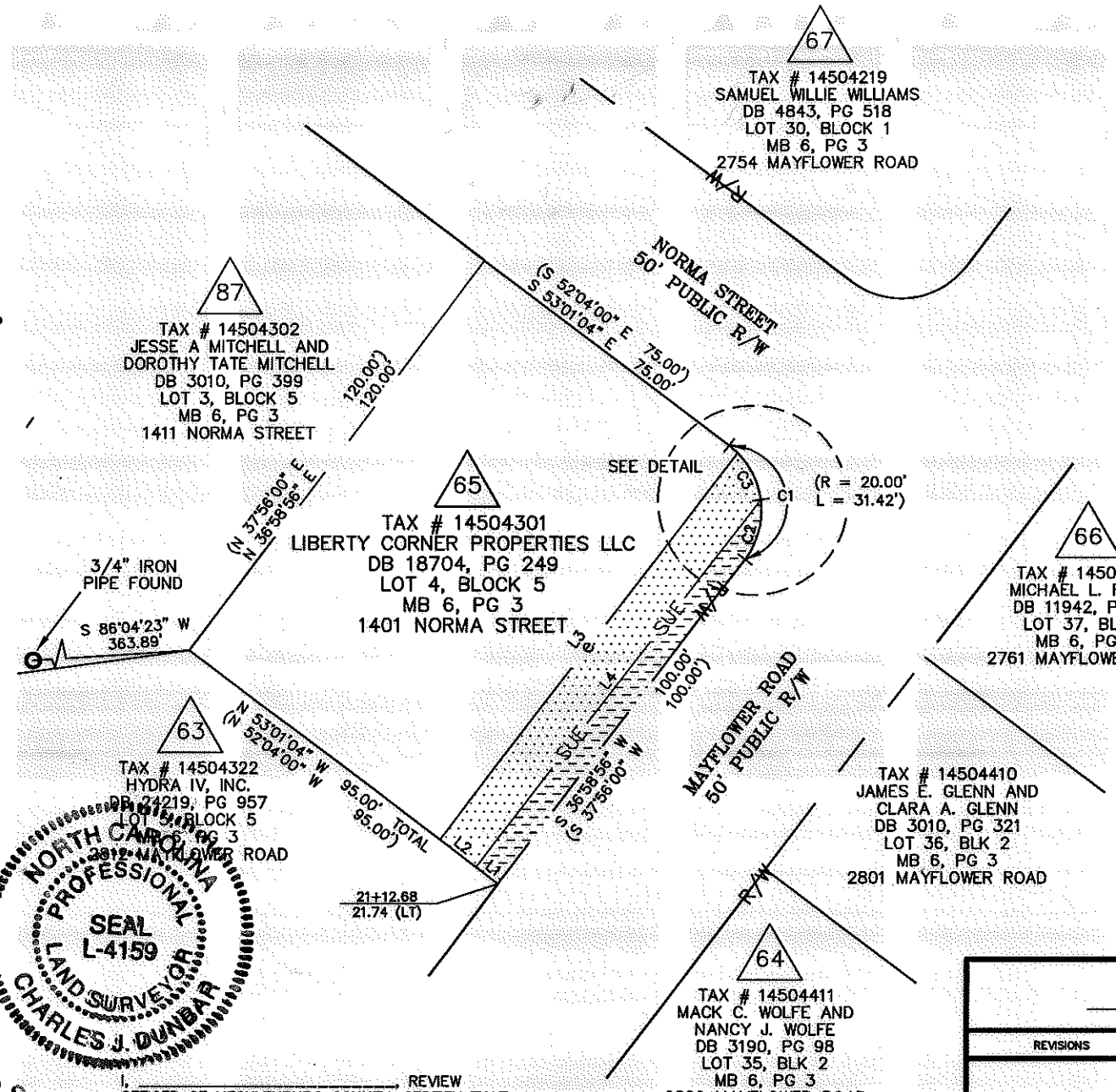

ACQUISITION BY DB 25948 PG 718