

I, DAVID H. SNIDER, CERTIFY THAT THIS PLAT WAS PREPARED UNDER MY SUPERVISION AND THAT THE PLAT WAS PREPARED FOR THE PURPOSE OF ACQUISITION AND EASEMENTS ONLY, AND IS NOT INTENDED TO BE A BOUNDARY SURVEY OF PROPERTY SHOWN.

David H. Snider 7/19/2010
 DAVID H. SNIDER, NC P.L.S. L-2942 DATE

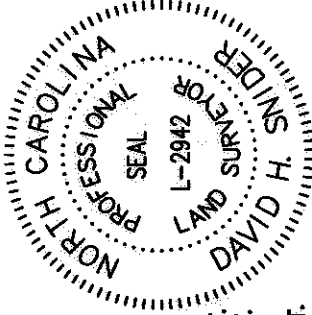

- NOTE:
- 1) BEARINGS AND DISTANCE SHOWN IN PARENTHESIS ARE BASED ON RECORDED INFORMATION.
 - 2) TOTAL AREA 183,226 SQ.FT.
 - 3) SIDEWALK/UTILITY EASEMENT 1,570 SQ.FT.
 - 4) UTILITY EASEMENT 55 SQ.FT.
 - 5) TEMP. CONSTRUCTION EASEMENT 15,435 SQ.FT.
 - 6) OVERLAP AREA 2,114 SQ.FT.
 - 7) TOTAL AREA REMAINING 183,226 SQ.FT.
 - 8) ROAD RIGHT-OF-WAY PREVIOUSLY RECORDED IN DEED BOOK 24927, PAGE 859.
 - 9) PER SHOPTON ROAD WEST R/W ABANDONED RESOLUTION BOOK 42, PAGE 292, THE OVERLAP AREA BELONGS TO R. HERNDON FREEMAN.
 - 10) SEE PAGE TWO FOR DETAILS.

STATE OF NORTH CAROLINA
 COUNTY OF MECKLENBURG

REVIEW OFFICER OF MECKLENBURG COUNTY, CERTIFY THAT THE MAP OR PLAT TO WHICH THIS CERTIFICATION IS AFFIXED MEETS ALL STATUTORY REQUIREMENTS FOR RECORDING.

REVIEW OFFICER _____ DATE _____

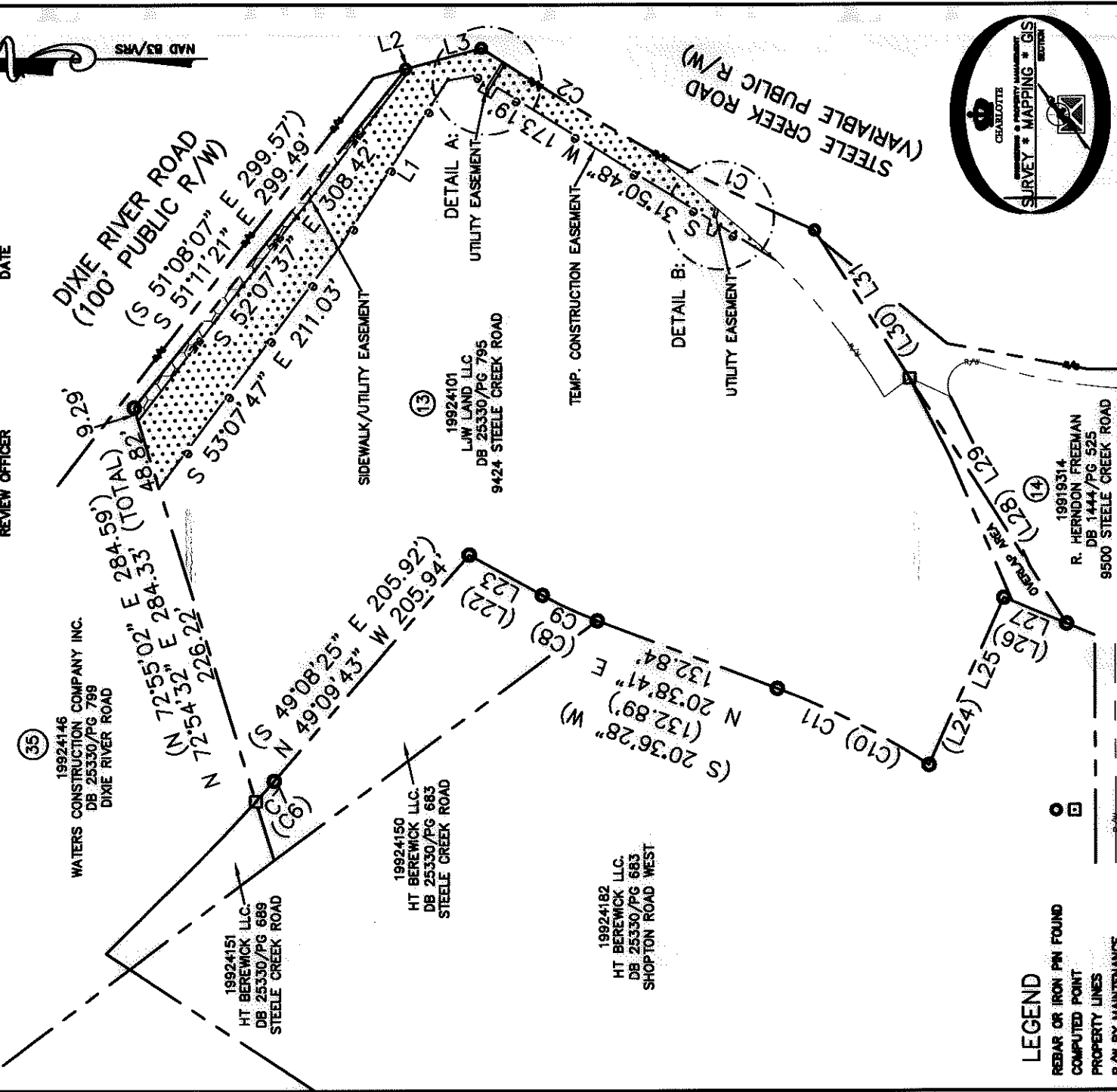
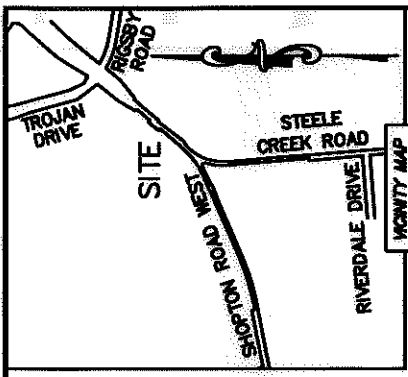

LEGEND

- REBAR OR IRON PIN FOUND
- COMPUTED POINT
- PROPERTY LINES
- R/W BY MAINTENANCE
- EXISTING RIGHT-OF-WAY
- UTILITY EASEMENT
- SIDEWALK/UTILITY EASEMENT
- TEMP. CONSTRUCTION EASEMENT
- UTILITY EASEMENT
- SIDEWALK/UTILITY EASEMENT
- TEMP. CONSTRUCTION EASEMENT

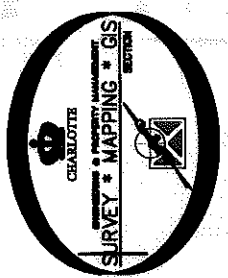

19919314
 R. HERNDON FREEMAN
 DB 1444/PG 525
 9500 STEELE CREEK ROAD

CHARLOTTE ENGINEERING DEPARTMENT	
REVISIONS	CHARLOTTE ENGINEERING DEPARTMENT
01/24/10 CHANGE EASEMENT & ADD NEW PROPERTY LINES	DIXIE RIVER ROAD REALIGNMENT
11/05/09 CHANGE TIE & UTILITY EASEMENT	PROPERTY ACQUISITION
0 SCALE 1" = 100'	OWNER: LJV LAND LLC.
DRAWN BY LG	CHARLOTTE, MECKLENBURG CO., NC
DATE	CHECKED BY DHS SURVEY SUPERVISOR
K:\AUTOCAD\en_su-104\204054\DWG\PARCEL 13.DWG	
JOB NO. 512-04-054	SHEET 1 OF 3
FILE NO. 199-241-01	

PREPARED BY:
 CITY OF CHARLOTTE
 ENGINEERING & PROPERTY MANAGEMENT
 600 EAST FOURTH STREET
 CHARLOTTE, NC 28202
 704-336-2291

ACQUISITION BY DB 25549 PG 106

I, DAVID H. SNIDER, CERTIFY THAT THIS PLAT WAS PREPARED UNDER MY SUPERVISION AND THAT THE PLAT WAS PREPARED FOR THE PURPOSE OF ACQUISITION AND EASEMENTS ONLY, AND IS NOT INTENDED TO BE A BOUNDARY SURVEY OF PROPERTY SHOWN.

David H. Snider
 DAVID H. SNIDER, NC P.L.S. L-2942 DATE 7/19/2010

STATE OF NORTH CAROLINA
 COUNTY OF MECKLENBURG

REVIEW OFFICER OF MECKLENBURG COUNTY, CERTIFY THAT THE MAP OR PLAT TO WHICH THIS CERTIFICATION IS AFFIXED MEETS ALL STATUTORY REQUIREMENTS FOR RECORDING.

REVIEW OFFICER _____ DATE _____

DETAIL A:
 (NOT TO SCALE)

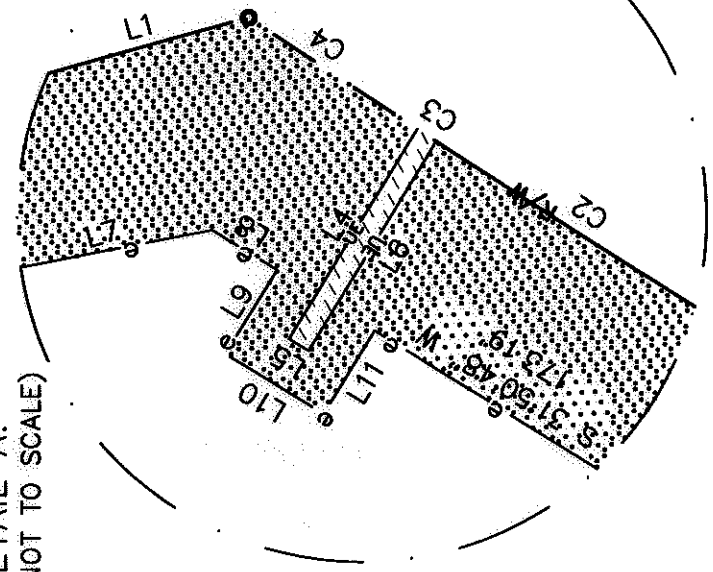

DETAIL B:
 (NOT TO SCALE)

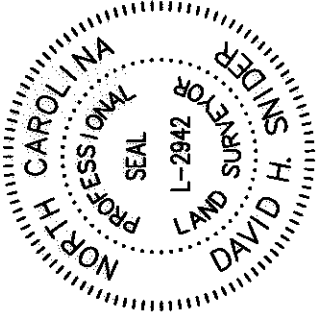
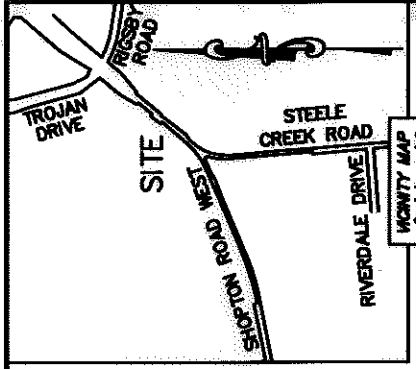
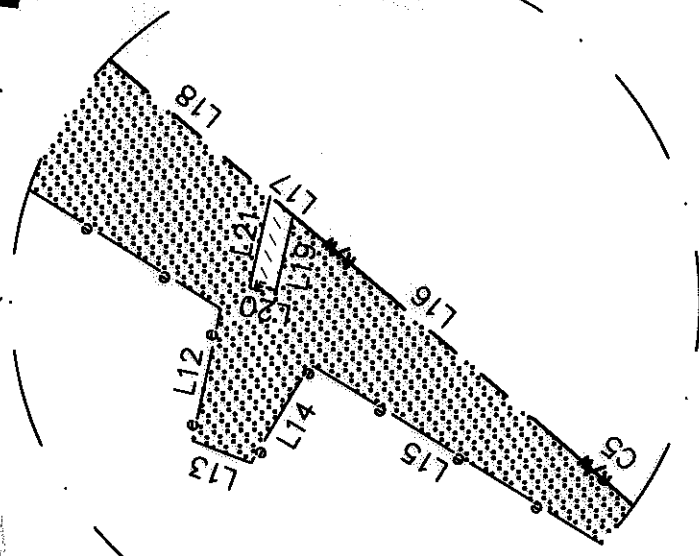

CURVE	RADIUS & ARC	CHORD
C1	R=1457.25 L=130.81'	S 26°06'57" W 130.76'
C2	R=1457.25 L=112.35'	S 30°53'46" W 112.33'
C3	R=1457.25 L=2.00'	S 33°08'39" E 2.00'
C4	R=1457.25 L=17.56'	S 33°31'43" W 17.56'
C5	R=1457.25 L=31.27'	S 41°46'09" W 31.27'
(C6)	(R=987.50 L=19.03')	(S 48°35'18" E 19.03')
C7	R=987.50 L=18.98'	N 48°35'37" W 18.98'
(C8)	(R=279.50 L=39.57')	(N 25°06'20" E 39.54')
C9	R=279.50 L=41.77'	N 24°54'01" E 41.73'
(C10)	(R=520.50 L=116.68')	(N 27°01'48" E 116.44')
C11	R=520.50 L=116.76'	N 27°00'23" E 116.51'

LEGEND

- REBAR OR IRON PIN FOUND
- COMPUTED POINT
- PROPERTY LINES
- EXISTING RIGHT-OF-WAY
- UTILITY EASEMENT
- SIDEWALK/UTILITY EASEMENT
- TEMP. CONSTRUCTION EASEMENT
- UTILITY EASEMENT
- SIDEWALK/UTILITY EASEMENT
- TEMP. CONSTRUCTION EASEMENT

PREPARED BY:
 CITY OF CHARLOTTE
 ENGINEERING & PROPERTY MANAGEMENT
 600 EAST FOURTH STREET
 CHARLOTTE, NC 28202
 704-336-2281

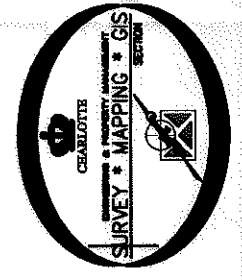

CHARLOTTE ENGINEERING DEPARTMENT		JOB NO. 512-04-064	SHEET 2
DIXIE RIVER ROAD REALIGNMENT		FILE NO. 199-241-01	OF 3
PROPERTY ACQUISITION OWNER: L&W LAND LLC.			
CHARLOTTE, MECKLENBURG CO., NC			
CHECKED BY: DHS SURVEY SUPERVISOR <i>DHS</i>			
DATE: _____			
K:\AUTOCAD\07_01--104\204054\DWG\PARCEL_13.DWG			

I, DAVID H. SNIDER, CERTIFY THAT THIS PLAT WAS PREPARED UNDER MY SUPERVISION AND THAT THE PLAT WAS PREPARED FOR THE PURPOSE OF ACQUISITION AND EASEMENTS ONLY, AND IS NOT INTENDED TO BE A BOUNDARY SURVEY OF PROPERTY SHOWN.

David H. Snider 11/10/2010
 DAVID H. SNIDER, NC P.L.S. L-2942 DATE

STATE OF NORTH CAROLINA
 COUNTY OF MECKLENBURG

REVIEW OFFICER OF MECKLENBURG COUNTY, CERTIFY THAT THE MAP OR PLAT TO WHICH THIS CERTIFICATION IS AFFIXED MEETS ALL STATUTORY REQUIREMENTS FOR RECORDING.

REVIEW OFFICER _____ DATE _____

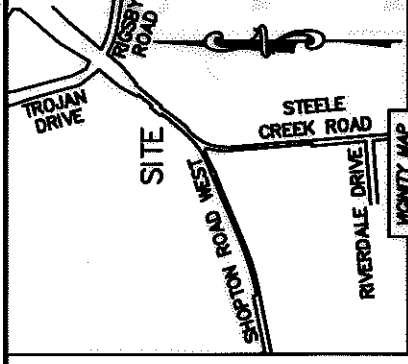
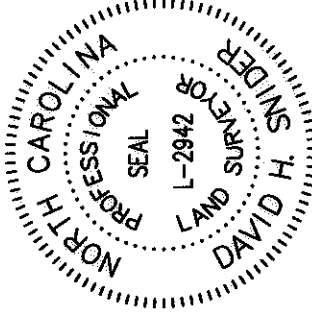

LINE TABLE		
LINE	LENGTH	BEARING
L1	133.68'	S 57°02'07" E
L2	4.54'	S 15°29'39" E
L3	49.43'	S 15°29'39" E
L4	21.34'	N 58°27'08" W
L5	2.00'	S 31°32'52" E
L6	21.29'	S 58°27'08" E
L7	20.52'	S 10°57'41" E
L8	6.57'	S 31°50'48" W
L9	8.55'	N 58°27'08" W
L10	10.00'	S 31°32'52" W
L11	8.50'	S 58°27'08" E
L12	10.13'	N 77°45'26" W
L13	4.69'	S 20°52'04" W
L14	8.65'	S 58°52'36" E
L15	46.53'	S 31°50'48" W
L16	22.93'	S 40°21'01" W
L17	2.25'	S 40°21'01" W
L18	64.40'	S 40°21'01" W
L19	5.72'	N 76°58'44" W
L20	2.00'	N 13°01'16" E
L21	6.76'	S 76°58'44" E
(L22)	(57.46')	(S 29°09'40" W)
L23	57.44'	N 29°07'07" E
(L24)	(126.42')	(S 65°39'07" E)
L25	126.44'	N 65°40'28" W
(L26)	(46.76')	(S 22°39'24" W)
L27	40.78'	N 22°50'22" E
(L28)	(199.32')	(S 57°38'14" W)
L29	201.01'	S 57°35'44" W
(L30)	(122.26')	(S 57°38'14" W)
L31	120.91'	S 57°35'44" W

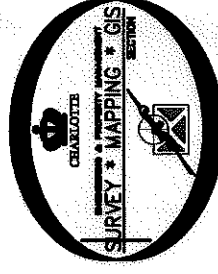

PREPARED BY:
 CITY OF CHARLOTTE
 ENGINEERING & PROPERTY MANAGEMENT
 600 EAST FOURTH STREET
 CHARLOTTE, NC 28202
 704-336-2281

CHARLOTTE ENGINEERING DEPARTMENT		JOB NO. 512-04-054	SHEET 3
		FILE NO. 199-241-01	OF 3
REVISIONS 02/04/10-CHANGE EASEMENT & ADD NEW PROPERTY LINES. 11/05/09-CHANGE TIE & USE EASEMENT		DIXIE RIVER ROAD REALIGNMENT	
DRAWN BY LG DATE		PROPERTY ACQUISITION OWNER: LJW LAND LLC. CHARLOTTE, MECKLENBURG CO., NC	
K:\AUTOCAD\en_gu-104\204054\DWG\PARCEL 13.DWG		CHECKED BY DHS SURVEY SUPERVISOR [Signature]	