

I, DAVID H. SNIDER, CERTIFY THAT THIS PLAT WAS PREPARED UNDER MY SUPERVISION AND THAT THE PLAT WAS PREPARED FOR THE PURPOSE OF ACQUISITION AND EASEMENTS ONLY, AND IS NOT INTENDED TO BE A BOUNDARY SURVEY OF PROPERTY SHOWN.

*David H. Snider* 8/15/08  
 DAVID H. SNIDER, NC P.L.S. L-2942 DATE

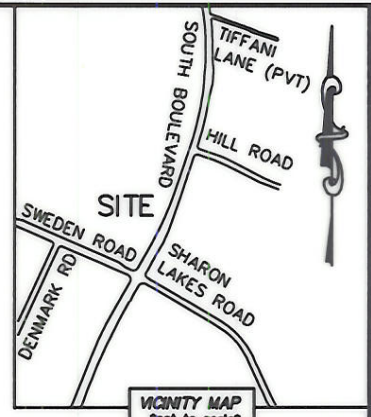
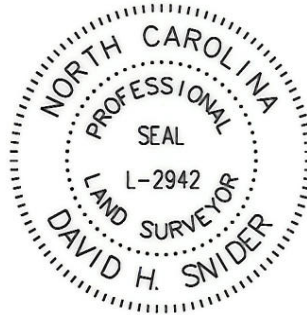

STATE OF NORTH CAROLINA  
 COUNTY OF MECKLENBURG

I, \_\_\_\_\_ REVIEW OFFICER OF MECKLENBURG COUNTY, CERTIFY THAT THE MAP OR PLAT TO WHICH THIS CERTIFICATION IS AFFIXED MEETS ALL STATUTORY REQUIREMENTS FOR RECORDING.

REVIEW OFFICER \_\_\_\_\_ DATE \_\_\_\_\_

20517S03  
 NORFOLK SOUTHERN  
 RAILWAY COMPANY  
 MB 40/PG 693  
 SOUTH BOULEVARD

**LEGEND**

REBAR OR IRON PIN FOUND	○
#5 REBAR SET	●
COMPUTED POINT	□
PROPERTY LINES	— — — — —
EXISTING ROAD RIGHT-OF-WAY	— — — — —
TEMP. CONSTRUCTION EASEMENT	— e — e —
FEE SIMPLE	— — — — —
NORFOLK-SOUTHERN RIGHT-OF-WAY	— — — — —
SIDEWALK/UTILITY EASEMENT	SUE — SUE
STORM DRAINAGE EASEMENT	SDE — SDE
FEE SIMPLE ACQUIRED	[Hatched Box]
TEMP. CONSTRUCTION EASEMENT	[Dotted Box]
SIDEWALK/UTILITY EASEMENT	[Cross-hatched Box]
STORM DRAINAGE EASEMENT	[Diagonal-hatched Box]

NC GRID MAD 83/2001

20516516  
 JIMMIE REITZEL &  
 WIFE BARBARA ANNE REITZEL  
 AND HARRY B. DOSTER &  
 WIFE NELL F. DOSTER  
 DB 6469/PG 528  
 SOUTH BOULEVARD

20517302  
 EXCHANGE AT NO 1 INC AND  
 JERRY N. HELMS AND WIFE SUSAN HELMS  
 DB 20191/PG 315  
 ENGLAND STREET

20516504  
 CITY OF CHARLOTTE  
 DB 4147/PG 370  
 4600 SWEDEN ROAD

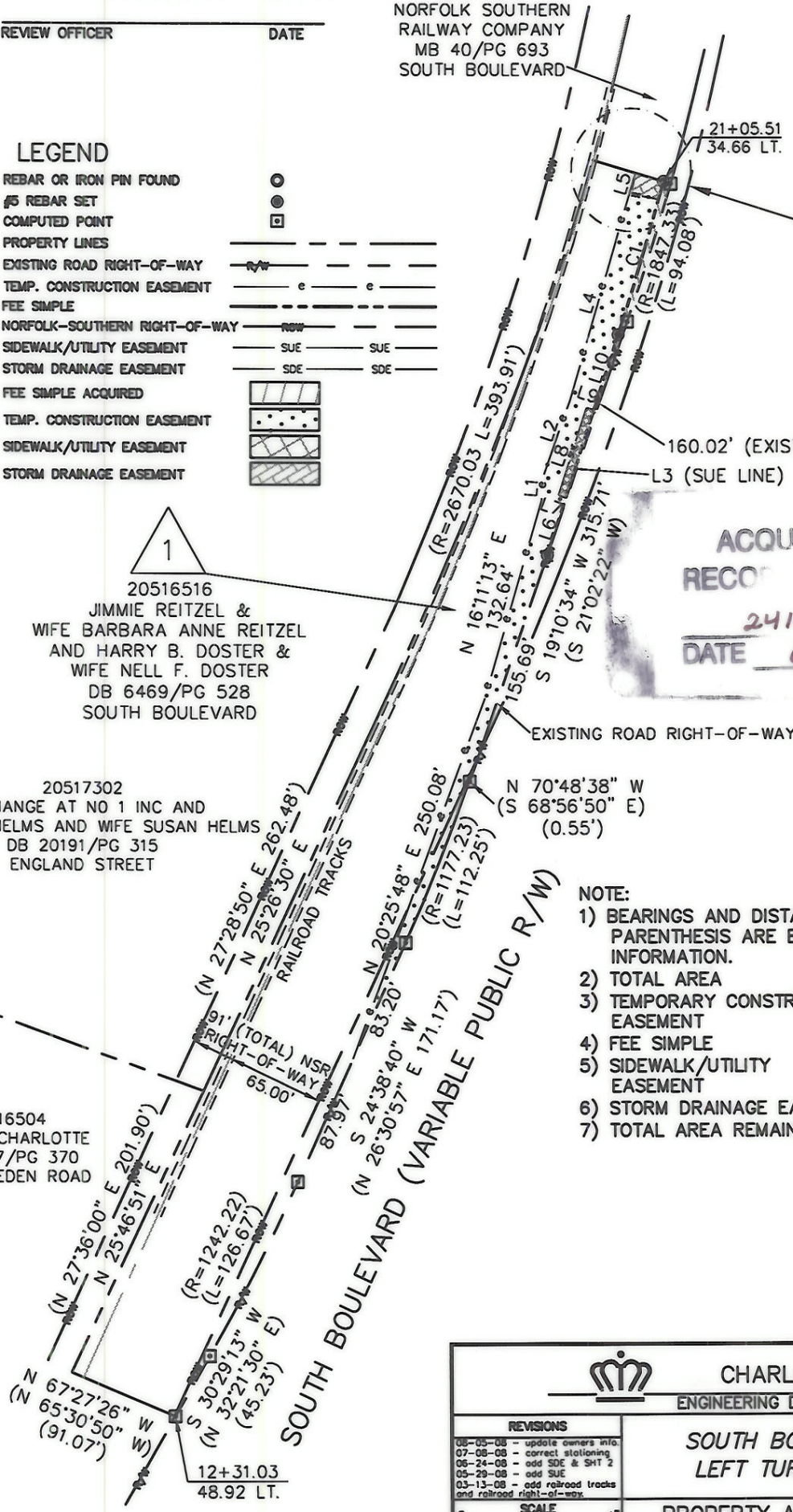

ACQUISITION BY CITY  
 RECORDED BOOK  
 24160-201  
 DATE 09-30-08

NOTE:

1) BEARINGS AND DISTANCE SHOWN IN PARENTHESIS ARE BASED ON RECORDED INFORMATION.	
2) TOTAL AREA	59,857 SQ.FT.
3) TEMPORARY CONSTRUCTION EASEMENT	6,797 SQ.FT.
4) FEE SIMPLE	619 SQ.FT.
5) SIDEWALK/UTILITY EASEMENT	297 SQ.FT.
6) STORM DRAINAGE EASEMENT	241 SQ.FT.
7) TOTAL AREA REMAINING	59,238 SQ.FT.



PREPARED BY:  
 CITY OF CHARLOTTE  
 ENGINEERING & PROPERTY MANAGEMENT  
 600 EAST FOURTH STREET  
 CHARLOTTE, NC 28202  
 704-336-2291

		JOB NO. 512-05-041
CHARLOTTE ENGINEERING DEPARTMENT		FILE NO. 205-165-16
<b>SOUTH BOULEVARD LEFT TURN LANE</b>		SHEET 1
PROPERTY ACQUISITION OWNERS: JIMMIE REITZEL & WIFE BARBARA ANNE REITZEL AND HARRY B. DOSTER & WIFE NELL F. DOSTER CHARLOTTE, MECKLENBURG CO., NC		OF 2
REVISIONS 06-05-08 - update owners info. 07-08-08 - correct stationing 08-24-08 - add SDE & SHT 2 09-29-08 - add SUE 03-13-09 - add railroad tracks and railroad right-of-way.	SCALE 1"=100'	DATE _____ CHECKED BY DHS SURVEY SUPR. <i>DHS</i>
DRAWN BY LG		K: \AUTOCAD\EN_SU-LD4\205041\DWG\PLAT 1.DWG

I, DAVID H. SNIDER, CERTIFY THAT THIS PLAT WAS PREPARED UNDER MY SUPERVISION AND THAT THE PLAT WAS PREPARED FOR THE PURPOSE OF ACQUISITION AND EASEMENTS ONLY, AND IS NOT INTENDED TO BE A BOUNDARY SURVEY OF PROPERTY SHOWN.

*David H. Snider* 8/5/09  
 DAVID H. SNIDER, NC P.L.S. L-2942 DATE

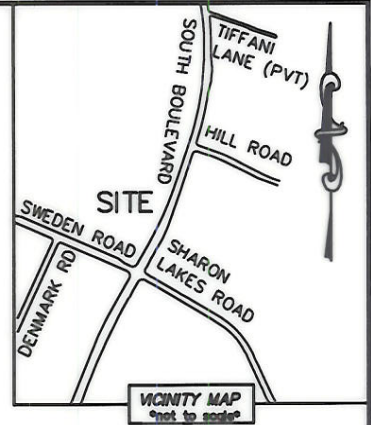

STATE OF NORTH CAROLINA  
 COUNTY OF MECKLENBURG

I, \_\_\_\_\_, REVIEW OFFICER OF MECKLENBURG COUNTY, CERTIFY THAT THE MAP OR PLAT TO WHICH THIS CERTIFICATION IS AFFIXED MEETS ALL STATUTORY REQUIREMENTS FOR RECORDING.

REVIEW OFFICER \_\_\_\_\_ DATE \_\_\_\_\_

NC GRID MAD 03/2001

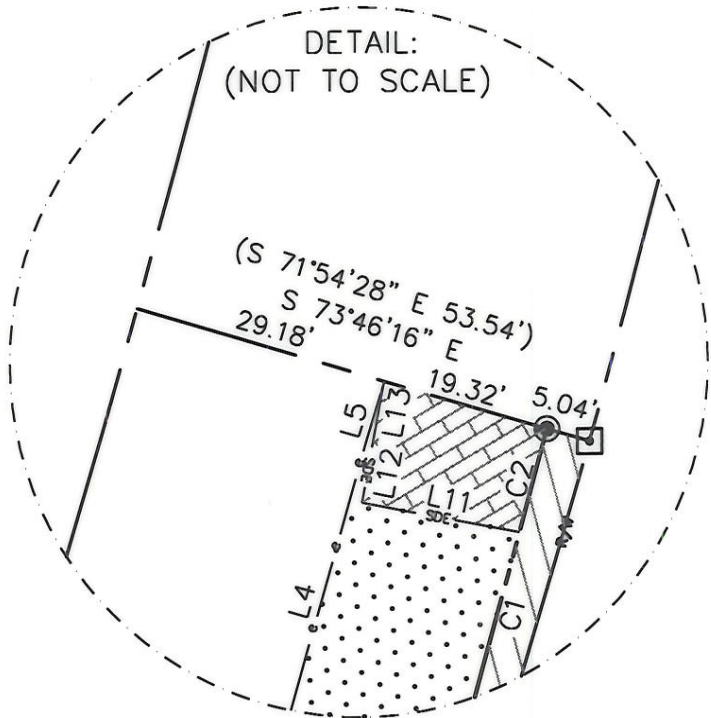

LINE TABLE		
LINE	LENGTH	BEARING
L1	17.42'	N 06°18'56" E
L2	49.88'	N 19°37'08" E
L3	59.47'	N 18°06'37" E
L4	147.58'	N 16°11'13" E
L5	6.29'	N 17°24'14" E
L6	38.81'	N 18°06'37" E
L7	5.00'	N 70°00'00" W
L8	59.32'	N 18°06'27" E
L9	5.00'	S 71°42'10" E
L10	51.75'	N 18°06'37" E
L11	18.26'	N 79°21'53" W
L12	13.35'	N 10°38'07" E
L13	0.45'	N 10°38'07" E

CURVE TABLE			
LINE	LENGTH	BEARING	RADIUS & ARC
C1	103.94'	N 16°37'04" E	R=1995.50 L=103.96'
C2	11.95'	N 15°17'48" E	R=1995.50 L=11.95'



PREPARED BY:  
 CITY OF CHARLOTTE  
 ENGINEERING & PROPERTY MANAGEMENT  
 600 EAST FOURTH STREET  
 CHARLOTTE, NC 28202  
 704-336-2291

REVISIONS		JOB NO. 512-05-041
08-05-08 - update owners info. 07-08-08 - correct stationing 06-24-08 - add SDE & SHT 2 05-29-08 - add SUE 03-13-08 - add railroad tracks and railroad right-of-way.		
SOUTH BOULEVARD LEFT TURN LANE		SHEET 2
PROPERTY ACQUISITION OWNERS: JIMMIE REITZEL & WIFE BARBARA ANNE REITZEL AND HARRY B. DOSTER & WIFE NELL F. DOSTER CHARLOTTE, MECKLENBURG CO., NC		OF 2
DRAWN BY LG	CHECKED BY DHS SURVEY SUPVR. <i>DHS</i>	
DATE _____		
K:\AUTOCAD\EN_SU-LD4\205041\DWG\PLAT 1.DWG		