

Conditional Zoning Notes

- Boundary survey by Russell Courtney & Associates, registered land surveyors, dated June 15, 1998. Topographic information from City of Charlotte digital topographic maps.
- Property will be developed as a single family cluster subdivision. All uses, together with all accessory and incidental uses permitted within the R-5 zoning district shall be allowed. Deed restrictions shall be placed on all lots prohibiting them from ever being rezoned to a multi-family district.
- All development standards established for the R-5 zoning district under the City Zoning Ordinance shall be met. In addition, the development shall also be governed by information on the Conditional Rezoning Plan.
- The street and lot layout shown on this plan is schematic in nature only. Site layout may be modified during final site design, so as to adhere to all requirements of the Conditional Rezoning Plan. Subdivision layout subject to review and approval by Charlotte Mecklenburg Planning Commission and Charlotte Engineering Department.
- All streets shall be public, with curb, gutter, and sidewalk. Streets shall be constructed to City of Charlotte standards.
- The subdivision will be served by public (CMUD) water and sanitary sewer. Fire protection in the form of fire hydrants will be provided.
- The property shown is NOT in a special flood hazard area, per FEMA Community Panel 370159 0014-B, dated 2/26/82. However, 100 year flood studies shall be prepared by a registered engineer for the existing drainage ditch along the northeastern property line. All new homes shall be constructed a minimum of one foot above the 100 year flood elevation. Improvements to drainage within the ditch shall be made in coordination with Charlotte Mecklenburg Storm Water Services, and as permitted by the United States Army Corps of Engineers and the North Carolina Department of Environment and Natural Resources. Bio-engineering techniques shall be employed where feasible to improve drainage flow along the creek.
- The petitioner shall coordinate all stream bank improvements and stabilization with the City of Charlotte Storm Water Services, and shall contribute 50% of the construction costs for the improvements, up to a maximum of \$67,512. Storm Water Services shall provide the surveying, design, and permitting of the stream bank improvements and shall administer the contract for the improvements. The petitioner shall provide a permanent storm drainage easement along the drainage way, measured 50 feet from top of bank or 50 feet from property line, whichever is greater, to give the City's contractor access for the improvements. The City shall be responsible for acquiring all off-site easements for lots that back up to the areas of proposed drainage way improvements.
- The rear yards of all lots shall be located outside the 50 foot permanent drainage easement (PDE) along the perimeter drainage channel. "Stems" for "flag lots" may encroach up to 25 feet into the 50 foot PDE, however, all driveways will be located outside the 50' PDE through the use of shared driveways. A minimum of 25 feet continuous common open space shall be reserved along the entire channel, as shown on plan. No fill material shall be placed in the 50 foot PDE behind the lots backing up to the drainage channel.
A minimum of 2.5 acres of common open space shall be preserved. Improvements to common open space shall be limited to "passive recreation" uses, such as walking trails and picnic areas. Common open space along the creek shall remain undisturbed, except for necessary drainage improvements and walks, paths or other passive recreation features. The petitioner agrees to plant 3'-4' tall Leyland Cypress at 25 feet maximum on center in areas along the stream north of Clardy Court that have been cleared from streambank stabilization construction by the City of Charlotte. The petitioner will also plant 3'-4' tall Leyland Cypress, or other similar evergreen trees, at 25 feet maximum on center along the entire stream channel south of Clardy Court.
- The 20' common open space shown along the property lines contiguous to adjacent lots along Sudbury Road, Downing Street, Wicklow Place, and Amesbury Avenue shall remain undisturbed and free of any passive recreational use. Deed restrictions shall be placed upon this common open space prohibiting its use by homeowners and prohibiting the removal of vegetation. However, the petitioner agrees to plant 15 large maturing evergreen shrubs in areas void of existing wooded vegetation within the common open space buffer adjacent to 2225 Downing Street (tax parcel 101-063-24), as shown on plan.
- Street trees shall be planted along all new streets. A minimum of one large maturing deciduous tree per lot shall be planted between the street right-of-way and building setback.
- All houses built within the subdivision shall be a minimum of 1000 square feet.
- A 25' class C buffer shall be preserved where the site abuts existing multi-family use along the northern property line. Buffer width may be reduced by 25% (to 18.75' wide) with construction of a 6' height solid wood fence, in compliance with zoning ordinance requirements. Buffer requirements shall be written into deed restrictions.
- Prior to any future changes to the Conditional Rezoning Plan, whether done administratively by Planning staff or through the public hearing process, the Charlotte East Community Partners, Inc. (Ms. Susan Lindsay, current chairwoman) shall be notified, so that the neighboring community may be aware of any proposed changes to the plan.
- All driveways to all lots shall be above the computed 100+1 flood elevation, to assure safe access to and from each dwelling unit.
- Masonry siding and masonry building materials may not be used in the construction of dwellings. All air conditioning units will be placed in rear yards. Roof pitches shall not be less than 4/12 pitch. Foundations shall be brick. Temporary sit fencing shall be erected by the developer wherever required by the City per approved erosion control plans.
- Grading shall be permitted in that area of the Common Open Space located between the 40' public street r/w and the 50 foot PDE shown on the plan.

Site Development Data

Existing Zoning	R-4
Proposed Zoning	R-5 (CD)
Tax Parcel No.	101-063-057 & 058
Deed Reference	4319-251 & 4607-812
Site Area	18.40 Acres
Max. Number of Lots	87
Min. Common Open Space	2.5 Ac. (13.5%)
Minimum Lot Area	4500 SF
Minimum Lot Width	40 Feet
Minimum Setback	20 Feet
Minimum Rear Yard	20 Feet (Interior Lots) 35 Feet (Exterior Lots)
Minimum Side Yard	6 Feet

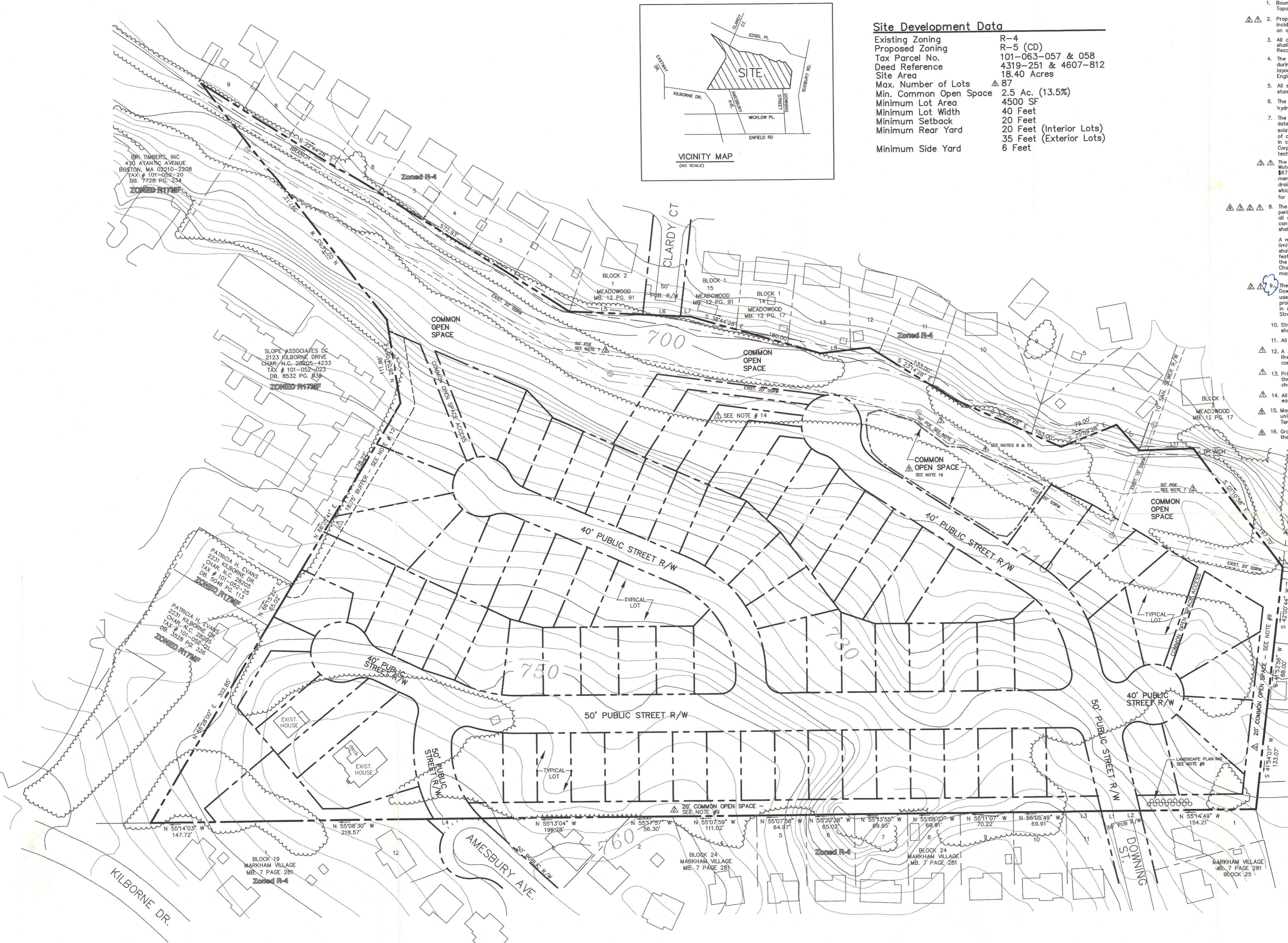
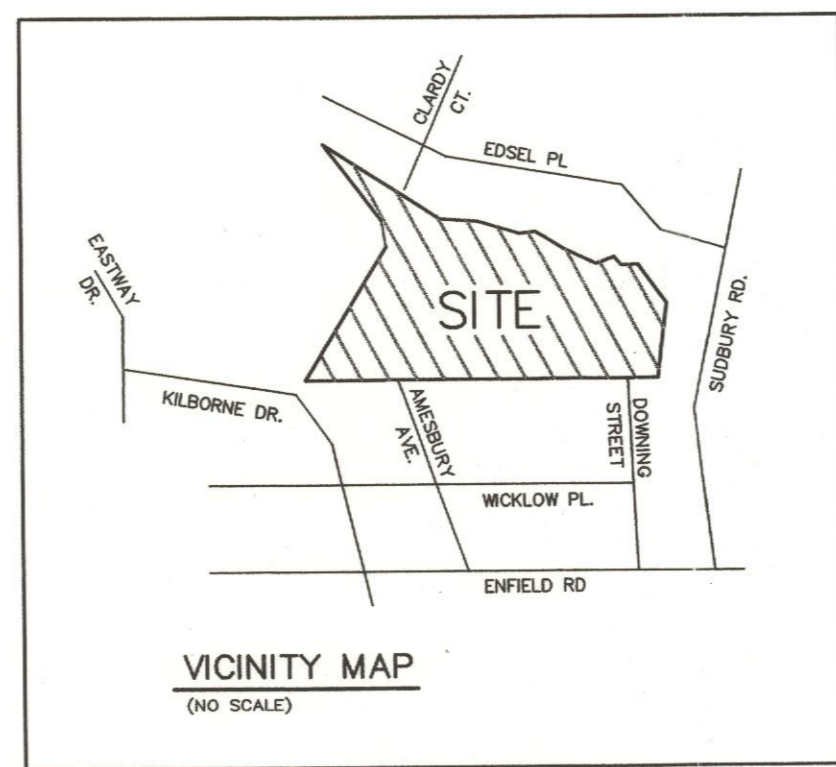

APPROVED BY CITY COUNCIL
DATE: 12-21-98

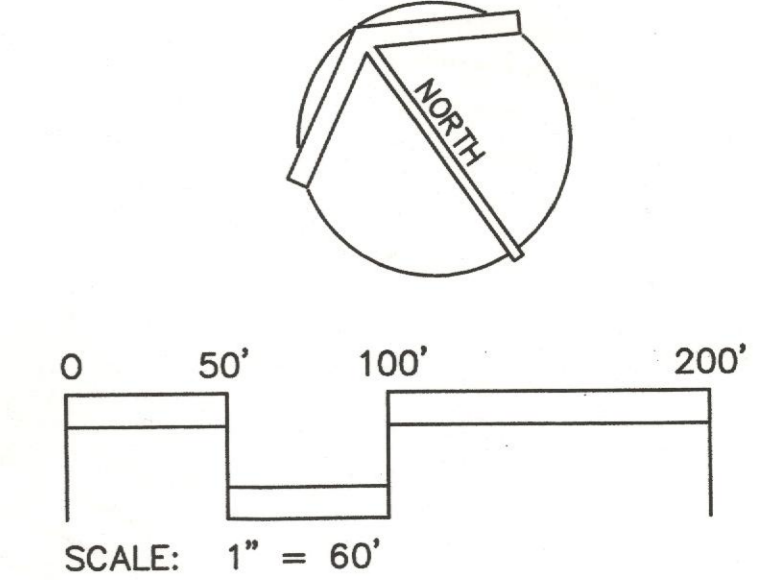

THIS SUBDIVISION PLAN IS SCHEMATIC IN NATURE AND INTENDED TO SHOW GENERAL DEVELOPMENT CHARACTER ONLY. ADJUSTMENTS IN STREET AND LOT LAYOUT WILL BE PERMITTED TO ACCOMMODATE FINAL SITE DESIGN AND TO ADJUST TO SITE FEATURES. UP TO 87 DETACHED SINGLE FAMILY LOTS MAY BE DEVELOPED ON THE SITE.

"FOR PUBLIC HEARING"

Rezoning Petition No. 98-90

Conditional Rezoning Plan

Windsor Forest
For Diamond Oak Development
Charlotte, North Carolina

4828 Carousal Drive
Charlotte, NC 28212
Phone: 704-566-0706
Fax: 704-567-0880

SITE DESIGN
S T U D I O

101 063 57, 58

NO.	DATE	DESCRIPTION
10/6/98		Per staff comments, neighborhood input, and client review
10/16/98		Per staff comments, neighborhood input, and client review
10/28/98		Revised notes 7 and 8; added 50' PDE along channel
12/11/98		Revised street and lot layout along drainage channel; revised note 8;
12/21/98		Revised lot layout; reduced lot count; added notes 15 & 16;

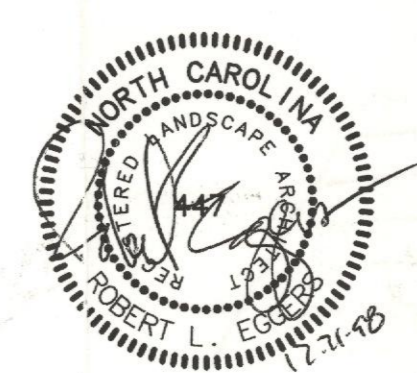

PROPERTY LINE TABLE

LINE	DIRECTION	DISTANCE
L1	N 54°51'48" W	24.83'
L2	N 54°51'48" W	26.13'
L3	N 55°13'30" W	46.33'
L4	N 55°08'30" W	72.76'
L5	S 52°14'28" E	97.11'
L6	S 52°14'28" E	50.12'
L7	S 52°14'28" E	12.77'
L8	S 61°14'28" E	65.00'
L10	S 05°49'28" E	45.00'
L11	S 56°39'28" E	72.00'