

SITE DATA TABLE	
LOCATION:	2023 BEATTIES FORD ROAD (PID: 06912627, 06912601)
EXISTING ZONING:	O-2 PED
PROPOSED ZONING:	B-1 (PED-O)
OWNER:	E-FIX DEVELOPMENT CO. LLC 201 N. MCDOWELL STREET CHARLOTTE, NC 28235
EXISTING FRONT SETBACK:	N/A
EXISTING SIDE SETBACK:	N/A
EXISTING REAR SETBACK:	N/A
FEMA MAP #	3710454500k
FEMA EFFECTIVE DATE	9/2/2015
SOIL TYPES	CU8
SITE LIGHTING BY OTHERS & SHALL COMPLY WITH LAND DEVELOPMENT STANDARDS	

LEGEND			
	PROJECT BOUNDARY		BUILDING HATCH
	PROPOSED BUILDING CURB AND GUTTER		FULL DEPTH ASPHALT
	BUILDING SETBACK		SIDEWALK
	IRRIGATION CONDUIT		HEAVY DUTY PAVEMENT
	EXISTING SURVEY		COMPACT CAR SPACE
	STOP SIGN W/ WHITE STOP BAR		PARKING ROW COUNT
			HANDICAPPED PARKING SYMBOL



VICINITY MAP
SCALE: N.T.S.

1. GENERAL PROVISIONS
 THESE DEVELOPMENT STANDARDS FORM PART OF THE REZONING PLAN ASSOCIATED WITH THE REZONING PETITION FILED BY E-FOX DEVELOPMENT CO. LLC (THE "PETITIONER") TO ACCOMMODATE THE DEVELOPMENT OF A PARKING FACILITY ON APPROXIMATELY 0.296-ACRE SITE, WHICH IS MORE PARTICULARLY DEPICTED ON THE REZONING PLAN (THE "SITE"). THE SITE IS COMPRISED OF TAX PARCEL NUMBERS 06912627, 06912601.

DEVELOPMENT OF THE SITE SHALL BE GOVERNED BY THE REZONING PLAN, THESE DEVELOPMENT STANDARDS AND THE APPLICABLE PROVISIONS OF THE CITY OF CHARLOTTE ZONING ORDINANCE (THE "ORDINANCE"). UNLESS THE REZONING PLAN OR THESE DEVELOPMENT STANDARDS ESTABLISH MORE STRINGENT STANDARDS, THE REGULATIONS ESTABLISHED UNDER THE ORDINANCE FOR THE B-1 (PED-O) ZONING DISTRICT SHALL GOVERN ALL DEVELOPMENT TAKING PLACE ON THE SITE.

THE DEVELOPMENT DEPICTED ON THE REZONING PLAN IS SCHEMATIC IN NATURE AND INTENDED TO DEPICT THE GENERAL ARRANGEMENT OF USES AND IMPROVEMENTS ON THE SITE. ACCORDINGLY, STRIPING, SIDEWALKS, DRIVEWAYS AND CURB PLACEMENTS DEPICTED ON THE REZONING PLAN ARE SCHEMATIC IN NATURE AND, SUBJECT TO THE TERMS OF THESE DEVELOPMENT STANDARDS AND THE ORDINANCE, ARE SUBJECT TO MINOR ALTERATIONS OR MODIFICATIONS DURING THE DESIGN DEVELOPMENT AND CONSTRUCTION DOCUMENT PHASES.

FUTURE AMENDMENTS TO THE REZONING PLAN AND/OR THESE DEVELOPMENT STANDARDS MAY BE APPLIED FOR BY THE THEN OWNER OR OWNERS OF THE SITE IN ACCORDANCE WITH THE PROVISIONS OF SECTION 6.207 OF THE ORDINANCE.

2. PURPOSE
 A) THE PURPOSE OF THIS ZONING APPLICATION IS TO PROPOSE A NEW PARKING FACILITY CONTAINING 20 PARKING SPOTS ALONG TAYLOR AVENUE TO SERVICE THE SITE ADJACENT TO THIS LOT.

B) TO ACHIEVE THIS PURPOSE, THE APPLICATION SEEKS THE REZONING OF THE SITE FROM O-2 TO B-1 (PED-O).

3. OPTIONAL PROVISIONS
 THE FOLLOWING OPTIONAL PROVISIONS SHALL APPLY TO THE SITE:
 A) TO ALLOW VEHICULAR PARKING AND CIRCULATION BETWEEN THE BUILDING AND TAYLOR AVENUE.

B) TO ALLOW CIRCULATION FOR A ACCESSORY DRIVE THRU LANE FOR A FINANCIAL INSTITUTIONAL BETWEEN THE BUILDING AND PUBLIC STREET.

C) TO PROVIDE A 5' SIDEWALK WITH 6' PLANTING STRIP ALONG LASALLE ST.

4. PERMITTED USES AND DEVELOPMENT
 THE SITE MAY BE DEVELOPED WITH PARKING SPACES, TOGETHER WITH ANY INCIDENTAL AND ACCESSORY USES RELATED THERETO THAT ARE ALLOWED IN THE B-1 (PED-O) ZONING DISTRICT.

5. TRANSPORTATION
 A) VEHICULAR ACCESS WILL BE AS GENERALLY DEPICTED ON THE REZONING PLAN. THE PLACEMENT AND CONFIGURATION OF THE VEHICULAR ACCESS POINT SHOWN ON THE REZONING PLAN IS SUBJECT TO ANY MINOR MODIFICATIONS REQUIRED TO ACCOMMODATE FINAL SITE AND CONSTRUCTION PLANS AND DESIGNS AND TO ANY ADJUSTMENTS REQUIRED BY NCDOT FOR APPROVAL.

B) AS DEPICTED ON THE REZONING PLAN, THE SITE WILL BE SERVED BY PUBLIC STREETS.

C) AS DEPICTED ON THE REZONING PLAN, PETITIONER WILL COMMIT TO CONSTRUCT 6-FT SIDEWALK ALONG ROAD FRONTAGE OF TAYLOR AVENUE. THE REZONING PLAN IS SUBJECT TO ANY MINOR MODIFICATIONS REQUIRED TO ACCOMMODATE FINAL SITE AND CONSTRUCTION PLANS AND DESIGNS AND TO ANY ADJUSTMENTS REQUIRED BY NCDOT FOR APPROVAL.

D) ROAD IMPROVEMENTS ALONG TAYLOR AVENUE WILL BE GENERALLY DEPICTED ON THE REZONING PLAN. FINAL DESIGN AND CONFIGURATION IS SUBJECT TO ANY MINOR MODIFICATIONS REQUIRED TO ACCOMMODATE FINAL SITE AND CONSTRUCTION PLANS AND DESIGNS AND TO ANY ADJUSTMENTS REQUIRED BY NCDOT FOR APPROVAL.

E) DEDICATION AND FEE SIMPLE CONVEYANCE OF ALL RIGHTS-OF-WAY TO THE CITY BEFORE THE SITE'S FIRST BUILDING CERTIFICATE OF OCCUPANCY IS ISSUED IS NEEDED. CDOT REQUESTS RIGHTS-OF-WAY SET AT 7' BEHIND BACK OF SIDEWALK WHERE FEASIBLE.

F) ALL TRANSPORTATION IMPROVEMENTS WILL BE APPROVED AND CONSTRUCTED BEFORE THE SITE'S FIRST BUILDING CERTIFICATE OF OCCUPANCY IS ISSUED IS NEEDED.

6. OPEN SPACE, STREETScape AND LANDSCAPING
 A) THE PETITIONER SHALL COMPLY WITH THE TREE ORDINANCE AND POST CONSTRUCTION STORMWATER ORDINANCE.

B) TREE SAVE IS REQUIRED AND THE SITE MUST DESIGNATE 22.5% OF THE SITE AREA AS TREE SAVE AREA. TREE SAVE AREA COMPLY WITH CHARLOTTE'S TREE ORDINANCE.

C) THIS CONDITIONAL PLAN IS NOT COMPLIANT WITH THE TREE ORDINANCE AS SHOWN. THE PROJECT WILL COMPLY WITH THE TREE ORDINANCE DURING THE LAND DEVELOPMENT PROCESS. THE PETITIONER ACKNOWLEDGES THAT CHANGES AND ALTERATIONS MAY BE NEEDED TO COMPLY WITH THE TREE ORDINANCE DURING PERMITTING. ALL CHANGES WOULD BE EVALUATED UNDER CHAPTER 6 OF THE ORDINANCE, AND MAY RESULT IN SUBSEQUENT REZONING.

7. LIGHTING
 A) ALL FREESTANDING LIGHTING FIXTURES INSTALLED ON THE SITE (EXCLUDING LOWER, DECORATIVE LIGHTING THAT MAY BE INSTALLED ALONG THE DRIVEWAYS AND SIDEWALKS AND LANDSCAPING LIGHTING) SHALL BE FULLY CAPPED AND SHIELDED AND THE ILLUMINATION DOWNWARDLY DIRECTED SO THAT DIRECT ILLUMINATION DOES NOT EXTEND PAST ANY PROPERTY LINE OF THE SITE.

B) THE MAXIMUM HEIGHT OF ANY FREESTANDING LIGHTING FIXTURES INSTALLED ON THE SITE, EXCLUDING STREET LIGHTS LOCATED ALONG PUBLIC STREETS, SHALL BE 22 FEET.

8. AMENDMENTS TO REZONING PLAN
 FUTURE AMENDMENTS TO THE TECHNICAL DATA SHEET OR THESE DEVELOPMENT STANDARDS MAY BE APPLIED FOR BY THE THEN OWNER OR OWNERS OF THE PARCEL OR PARCELS WITHIN THE SITE INVOLVED IN ACCORDANCE WITH THE PROVISIONS OF CHAPTER 6 OF THE ORDINANCE.

FURTHER ALTERATIONS OR MODIFICATIONS TO THIS REZONING PLAN WHICH, IN THE OPINION OF THE PLANNING DIRECTOR, SUBSTANTIALLY ALTER THE CHARACTER OF THE DEVELOPMENT OR SIGNIFICANTLY ALTER THE TECHNICAL DATA SHEET OR ANY OF ITS CONDITIONS OR WHICH INCREASE THE INTENSITY OF DEVELOPMENT SHALL NOT BE DEEMED TO BE MINOR AND MAY ONLY BE MADE IN ACCORDANCE WITH THE PROVISIONS OF SUBSECTIONS 6.207(1) OR (2) OF THE ORDINANCE, AS APPLICABLE.

9. ENVIRONMENTAL FEATURES
 A) DEVELOPMENT WITHIN ANY SWIM/PCSO BUFFER SHALL BE COORDINATED WITH AND SUBJECT TO APPROVAL BY CHARLOTTE-MECKLENBURG STORM WATER SERVICES AND MITIGATED IF REQUIRED BY CITY ORDINANCE.

B) DEVELOPMENT OF THE SITE SHALL COMPLY WITH THE TREE ORDINANCE.

10. BINDING EFFECT OF THE REZONING DOCUMENTS AND DEFINITIONS
 A) IF THE REZONING PLAN IS APPROVED, ALL CONDITIONS APPLICABLE TO DEVELOPMENT OF THE SITE IMPOSED UNDER THE TECHNICAL DATA SHEET WILL, UNLESS AMENDED IN THE MANNER PROVIDED UNDER THE ORDINANCE, BE BINDING UPON AND INURE TO THE BENEFIT OF THE PETITIONER AND THE CURRENT AND SUBSEQUENT OWNERS OF THE SITE AND THEIR RESPECTIVE SUCCESSORS IN INTEREST AND ASSIGNS.

B) THROUGHOUT THESE DEVELOPMENT STANDARDS, THE TERMS, "PETITIONER" AND "OWNER" AND "OWNERS" SHALL BE DEEMED TO INCLUDE THE HEIRS, DEVISEES, PERSONAL REPRESENTATIVES, SUCCESSORS IN INTEREST AND ASSIGNS OF THE PETITIONER OR THE OWNERS OF THE SITE FROM TIME TO TIME WHO MAY BE INVOLVED IN ANY FUTURE DEVELOPMENT THEREOF.

HensonFoley
 Landscape Architecture | Civil Engineering
 8712 Lindholm Dr Suite 202A, Huntersville, NC 28078
 p: 704.875.1615 | www.hensonfoley.com
 NC ENGINEERING BOARD LICENSE #: C09181
 NC LANDSCAPE ARCHITECTURE BOARD LICENSE #: C-399

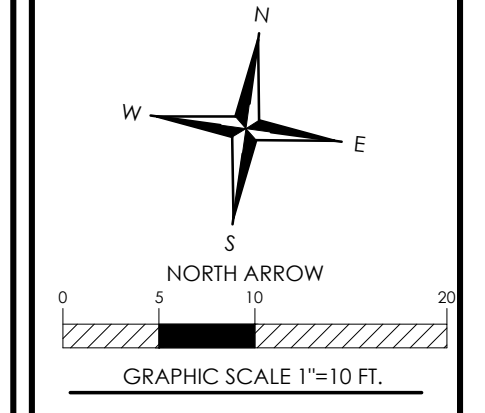

REZONING PLAN
 PID: 06912627, 06912601
 CHARLOTTE, NC
EX01-REZONING PLAN

REVISIONS:

2021-03-17	Charlotte Comments
2021-03-24	CDOT Comments

REZONING PLAN.DWG
 PROJECT NUMBER: 220030
 DATE: 1-14-2021 DRAWN BY: HFI
EX01
 SHEET